

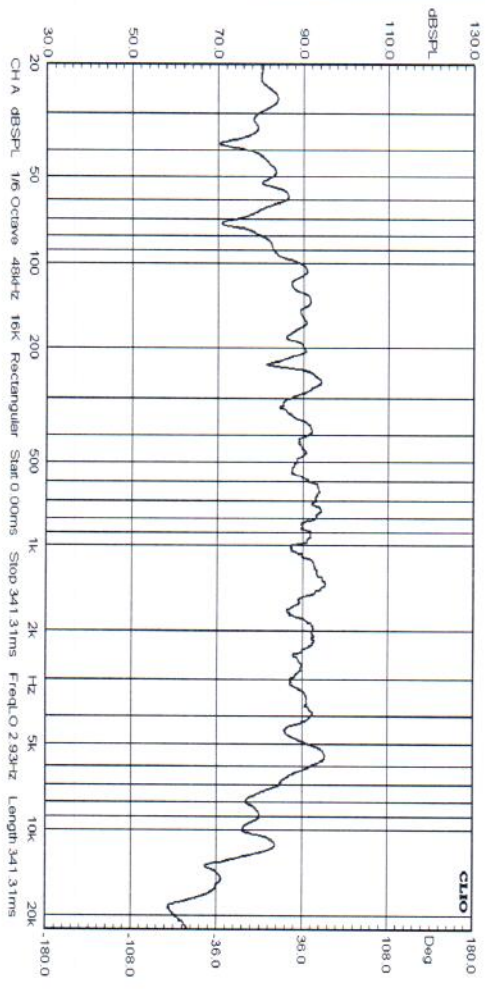

SPEAKER SPECIFICATIONS

Model Number:	C6515-4
GENERAL SPECIFICATIONS	
Nominal Diameter:	6.5 inch
Rated Impedance:	4 ohms
Operating Bandwidth:	50-7k hz (-3dB)
Power Handling Capacity:	125 Watts
Sensitivity (1W/M):	90 dB(+/-3dB)
Voice Coil Diameter:	1 inch
THIELE-SMALL PARAMETERS	
Resonance Frequency	Fs: 55.43 HZ
DC Resistance	Re: 3.4ohm
Mechanical Q Factor	Qms: 3,49
Electrical Q Factor	Qes: 1,07
Total Q Factor	Qts: 0,82
Equivalent Gas air load	Vas: 14.27 L
Surface Area of Cone	Sd: 0.0143 m ²
Efficiency Bandwidth Product	EBP 51,8
Voice Coil Over Hang	X-max 3 mm
PHYSICAL INFORMATION	
Basket:	Black Stamp Steel
Magnet Type:	20 OZ
Cone Material:	Injection PP
Surround:	Rubber
Dust Cap:	PP
Damper:	cloth

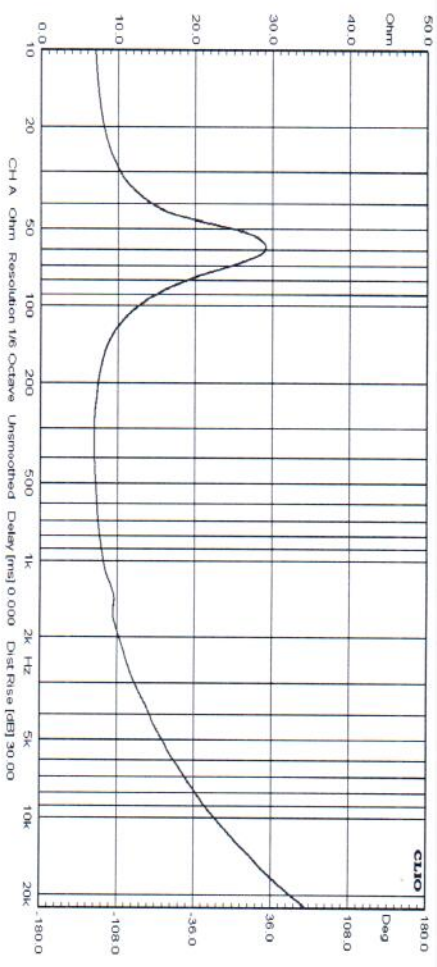

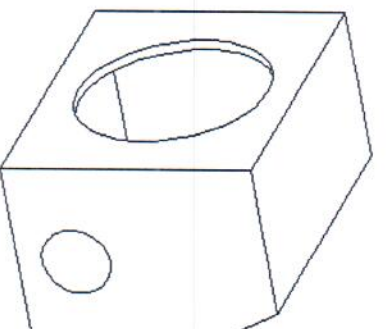
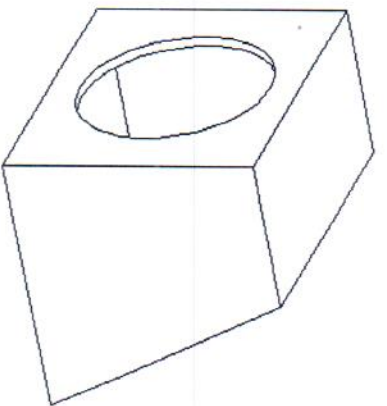
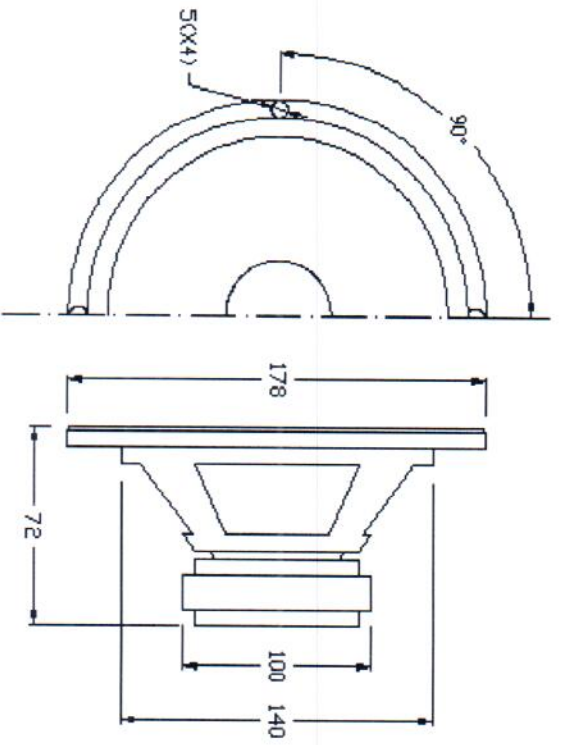

Sealed Box

Vented Box

Suggested enclosure parameters	Sealed		Vented	
	Small	Large	Small	Large
Enclosure volume, cu. ft.	0,5	NA	0,5	N
Vent length, inches	-	-	5,5	-
Vent diameter, inches	-	-	2,3	-
Enclosure Frequency, Hz	76	-	-	-
Fb Tuning Frequency of Vented Enclosure, Hz	NA	-	55	-
F3 Systems 3dB Down Piont(Sealed), Hz	60	-	-	-