

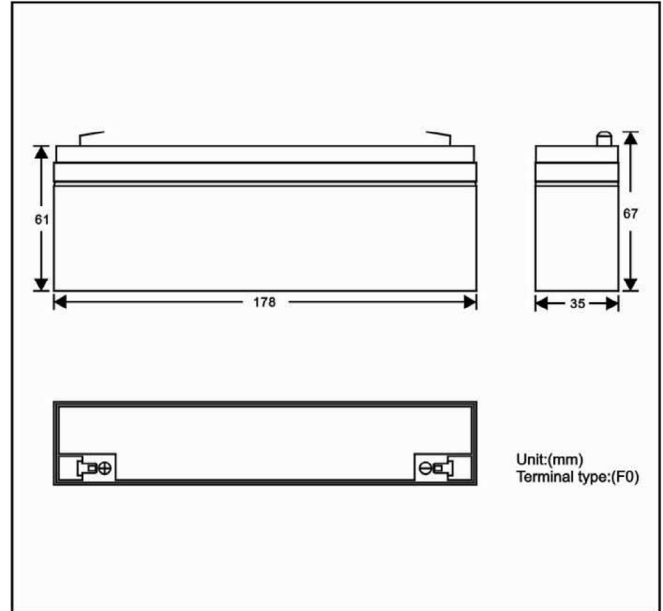

Akumulator żelowy VIPOW 12V 2.2Ah



Specifications

LP2.2-12		
Nominal Voltage	12V	
Rated Capacity (20 hours rate)	2.2Ah	
Dimension (±2mm)	Total Height (with terminals)	67mm
	Length	178mm
	Width Height	35mm 61mm
Weight (Approx)	0.95Kg	

Characteristics

Capacity	20 hours rate (0.11A)	2.2Ah
Discharge Current Testing (25°C)	20 I ₂₀ rate (2.2A, 27min) 60 I ₂₀ rate (6.6A, 7min)	38min 8min
Internal Resistance	Full Charged Battery 25°C	75mΩ
Capacity Affected By Temperature (20 hours rate)	40°C 25°C 0°C -15°C	102% 100% 85% 62%
Residual Capacity (25°C)	Capacity After 3 Months Storage Capacity After 6 Months Storage Capacity After 12 Months Storage	91% 82% 64%
Cycle (Above 300 Time)	Discharge 2hrs at 0.55A Current Charge 6hrs at 0.22A Current (25°C)	
Charge (Constant Voltage)	Cycle (25°C)	Initial Charging Current Less Than 0.66A; Voltage 14.5~14.9V
	Float (25°C)	Charge Voltage 13.6~13.8V

★ The above are average and date obtained from the first 3 charge/discharge cycles. These are not minimum values.

Discharge Current & Duration Time

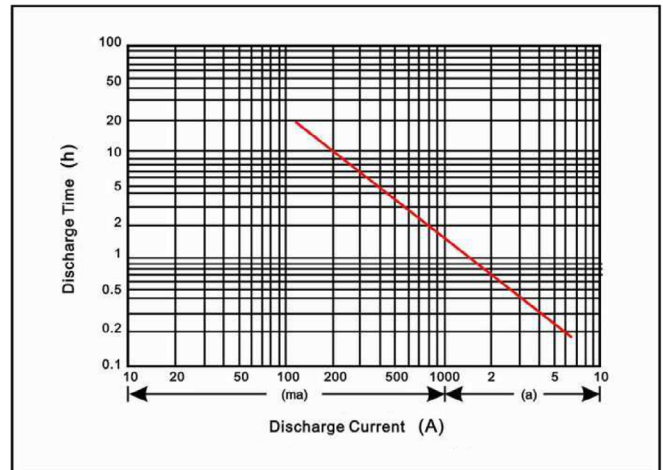

Discharge Current 25°C

