

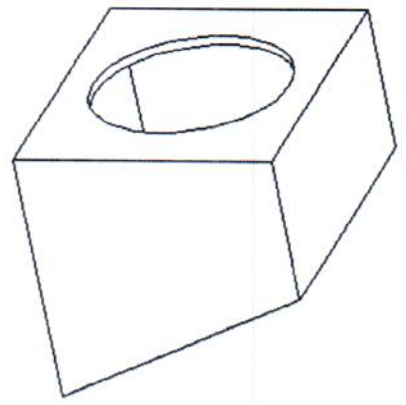

SPEAKER SPECIFICATIONS

Model Number:	G8003-8	
GENERAL SPECIFICATIONS		
Nominal Diameter:	8 inch	
Rated Impedance:	8 ohms	
Operating Bandwidth:	45-6k Hz (-3dB)	
Power Handling Capacity:	90 Watts	
Sensitivity (1W/M):	90 dB(+3dB)	
Voice Coil Diameter:	1 inch	
THIELE-SMALL PARAMETERS		
Resonance Frequency	Fs:	43.7 HZ
DC Resistance	Re:	6.8ohm
Mechanical Q Factor	Qms:	5, 4
Electrical Q Factor	Qes:	1, 15
Total Q Factor	Qts:	0, 95
Equivalent Gas air load	Vas:	40.12 L
Surface Area of Cone	Sd:	0.0139 m ²
Efficiency Bandwidth Product	EBP	57, 39
Voice Coil Over Hang	X-max	3 mm
PHYSICAL INFORMATION		
Basket:	Black Stamp Steel	
Magnet Type:	20 OZ	
Cone Material:	Paper	
Surround:	Foam	
Dust Cap:	Paper	
Damper:	cloth	

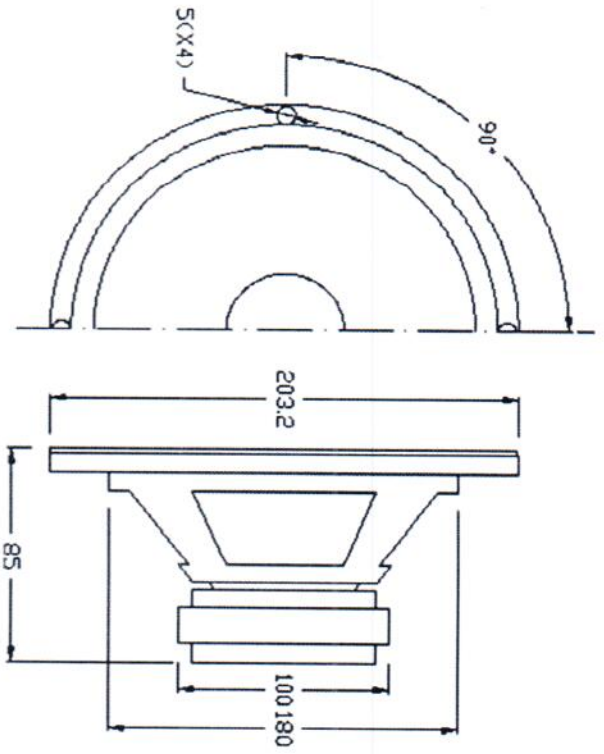

Sealed Box

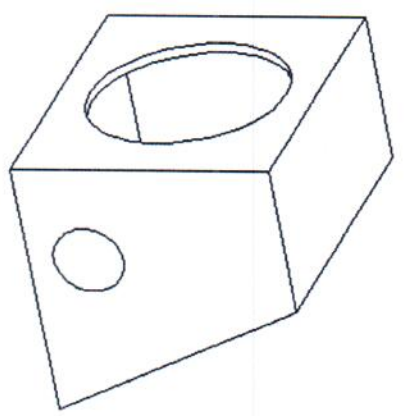

Vented Box

Suggested enclosure parameters	Sealed		Vented	
	Small	Large	Small	Large
Enclosure volume, cu. ft.	0,7	NA	0,7	NA
Vent length, inches	-	-	6,0	-
Vent diameter, inches	-	-	2,7	-
Enclosure Frequency, Hz	75	-	-	-
Fb Tuning Frequency of Vented Enclosure, Hz	NA	-	50	-
F3 Systems 3dB Down Piont (Sealed), Hz	58	-	-	-