



Model Number: P1207-WOOFER

GENERAL SPECIFICATIONS

Nominal Diameter:	12 inch
Rated Impedance:	4 ohms
Operating Bandwidth:	30-4k hz (-3dB)
Power Handling Capacity:	140 Watts
Sensitivity (1W/M):	91 dB(+/-3dB)
Voice Coil Diameter:	2.0 inch

THIELE-SMALL PARAMETERS

Resonance Frequency	Fs: 41.65 HZ
DC Resistance	Re: 3.6ohm
Mechanical Q Factor	Qms: 3,39
Electrical Q Factor	Qes: 0,93
Total Q Factor	Qts: 0,73
Equivalent Gas air load	Vas: 40.8 L
Surface Area of Cone	Sd: 0.0523 m2
Efficiency Bandwidth Product	FBP 44,4
Voice Coil Over Hang	X-max: 5 mm

PHYSICAL INFORMATION

Basket:	Black Stamp Steel
Magnet Type:	30 OZ
Cone Material:	Paper
Surround:	Foam
Dust Cap:	Paper
Damper:	cloth

SPEAKER SPECIFICATIONS

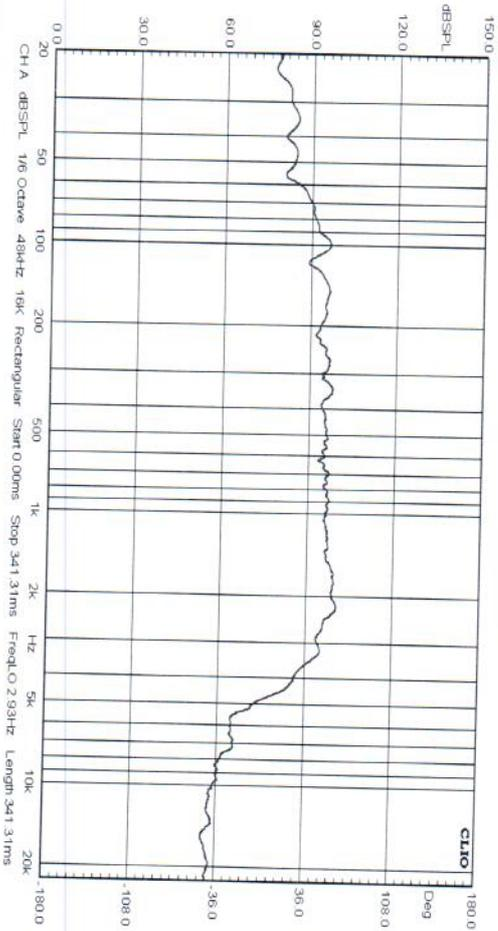
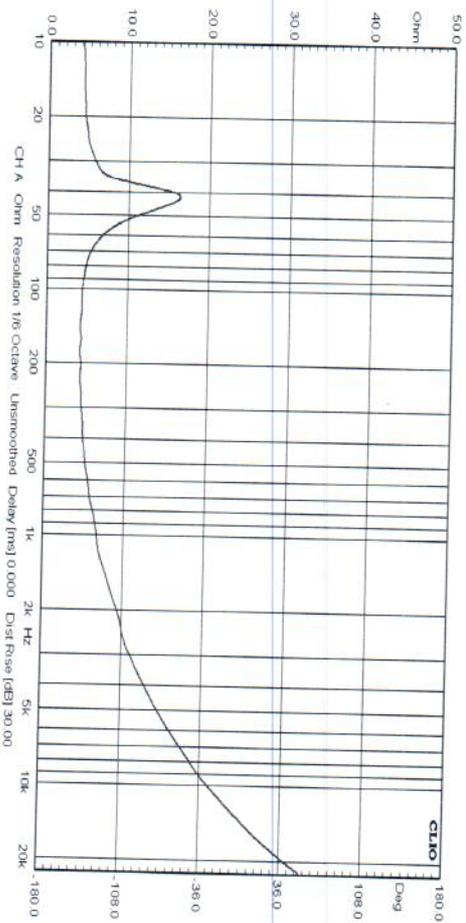

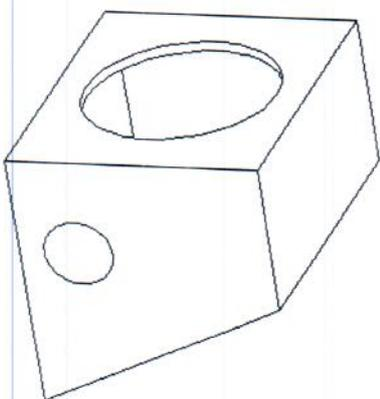
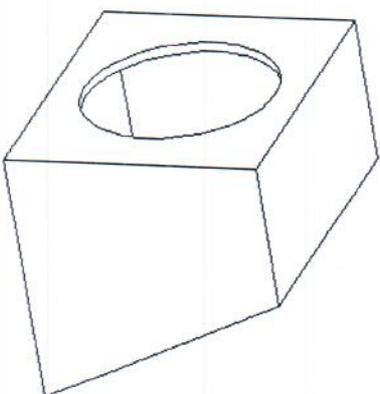
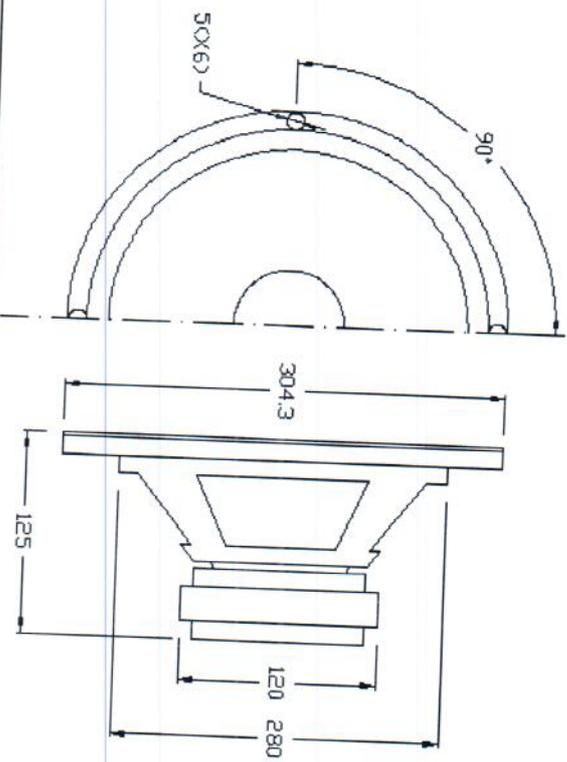

Sealed Box

Vented Box

Suggested enclosure parameters	Sealed		Vented	
	Small	Large	Small	Large
Enclosure volume, cu. ft.	1, 2	NA	1, 5	NA
Vent Length, inches	-	-	6, 0	-
Vent diameter, inches	-	-	3, 5	-
Enclosure Frequency, Hz	66	-	-	-
Fb Tuning Frequency of Vented Enclosure, Hz	NA	-	50	-
F3 Systems 3dB Down Piont (Sealed), Hz	49, 5	-	-	-