

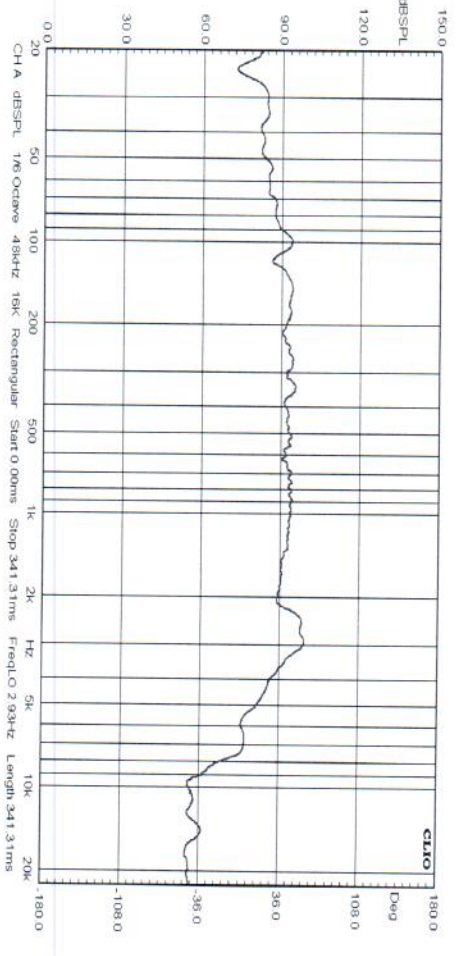

SPEAKER SPECIFICATIONS

Model Number:	P1007-WOOFER	
GENERAL SPECIFICATIONS		
Nominal Diameter:	10 inch	
Rated Impedance:	4 ohms	
Operating Bandwidth:	40-1k hz (-3dB)	
Power Handling Capacity:	110 Watts	
Sensitivity (1W/M):	91 dB(+3dB)	
Voice Coil Diameter:	2.0 inch	
THIELE-SMALL PARAMETERS		
Resonance Frequency	Fs:	41.65 HZ
DC Resistance	Re:	3.6ohm
Mechanical Q Factor	Qms:	3, 77
Electrical Q Factor	Qes:	1, 23
Total Q Factor	Qts:	0, 93
Equivalent Cas air load	Vas:	64.8 L
Surface Area of Cone	Sd:	0.0346 m2
Efficiency Bandwidth Product	EBP	33, 86
Voice Coil Over Hang	X-max	5 mm
PHYSICAL INFORMATION		
Basket:	Black Stamp Steel	
Magnet Type:	24 OZ	
Cone Material:	Paper	
Surround:	Foam	
Dust Cap:	Paper	
Damper:	cloth	

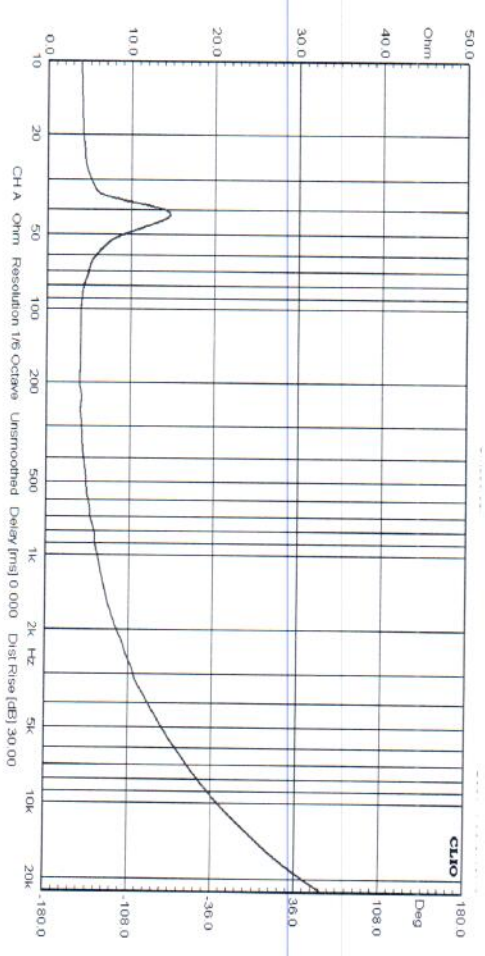

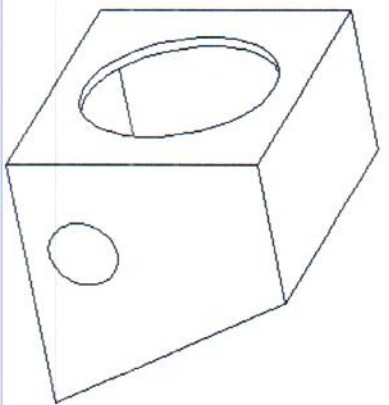
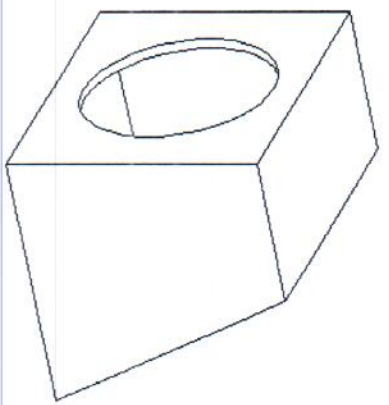
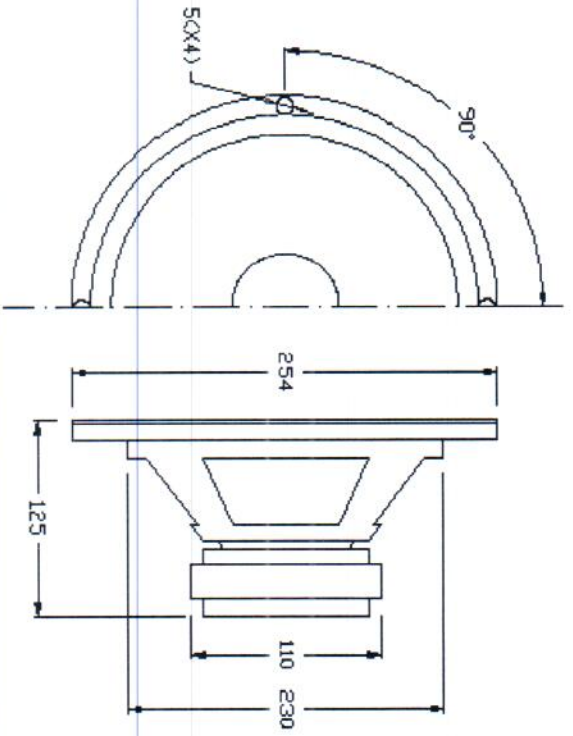

Sealed Box

Vented Box

Suggested enclosure parameters	Sealed		Vented	
	Small	Large	Small	Large
Enclosure volume, cu. ft.	1, 2	NA	1, 2	NA
Vent length, inches	-	-	5, 2	-
Vent diameter, inches	-	-	3, 0	-
Enclosure Frequency, Hz	55	-	-	-
Fb Tuning Frequency of Vented Enclosure, Hz	NA	-	50	-
F3 Systems 3dB Down Point (Sealed), Hz	42	-	-	-