



SPEAKER SPECIFICATIONS

Model Number:	G8002-8		
GENERAL SPECIFICATIONS			
Nominal Diameter:	8 inch		
Rated Impedance:	8 ohms		
Operating Bandwidth:	45-6k Hz (-3dB)		
Power Handling Capacity:	90 Watts		
Sensitivity (1W/M):	90 dB(+/-3dB)		
Voice Coil Diameter:	1 inch		
THIELE-SMALL PARAMETERS			
Resonance Frequency	Fs:	46.6 HZ	
DC Resistance	Re:	6.8ohm	
Mechanical Q Factor	Qms:	5, 4	
Electrical Q Factor	Qes:	1, 15	
Total Q Factor	Qts:	0, 95	
Equivalent Gas air load	Vas:	40.12 L	
Surface Area of Cone	Sd:	0.0139 m ²	
Efficiency Bandwidth Product	EBP	57, 39	
Voice Coil Over Hang	X-max	3 mm	
PHYSICAL INFORMATION			
Basket:	Black Stamp Steel		
Magnet Type:	20 Oz		
Cone Material:	Paper		
Surround:	Foam		
Dust Cap:	Paper		
Damper:	cloth		

CHA Ohm Resolution 1/6 Octave Unsmoothed Delay (ms) 0.000 Dist Rise (dB) 30.00

CHA dB SPL 1/6 Octave 48Hz 16K Rectangular Start 0.00ms Stop 341.31ms Freq 0.2 93Hz Length 341.31ms

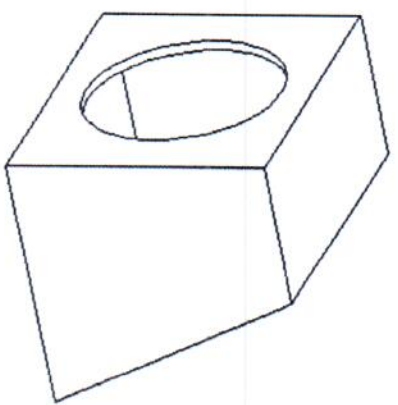
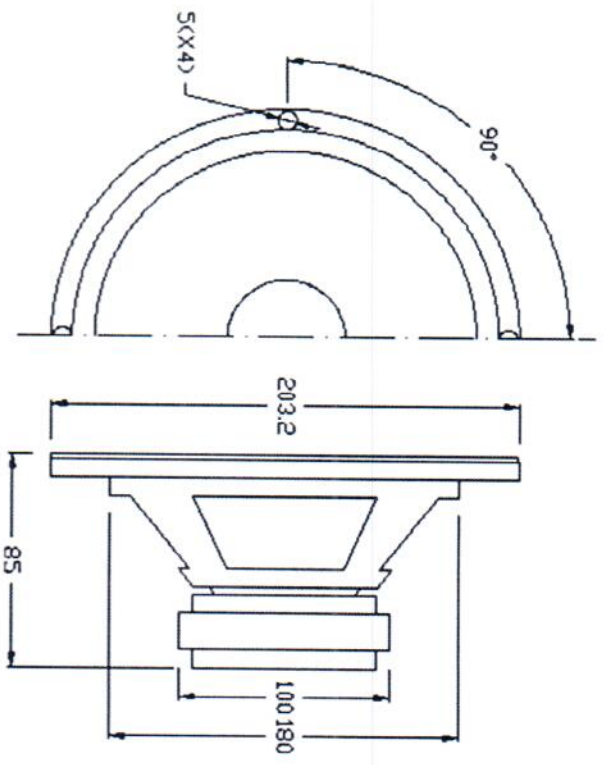

Sealed Box

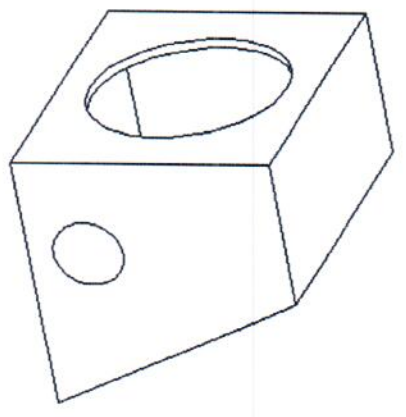

Vented Box

Suggested enclosure parameters	Sealed		Vented	
	Small	Large	Small	Large
Enclosure volume, cu. ft.	0,7	NA	0,7	NA
Vent length, inches	-	-	6,0	-
Vent diameter, inches	-	-	2,7	-
Enclosure Frequency, Hz	75	-	-	-
Fb Tuning Frequency of Vented Enclosure, Hz	NA	-	50	-
F3 Systems 3dB Down Piont (Sealed), Hz	58	-	-	-