



## SPEAKER SPECIFICATIONS

<b>Model Number:</b>	G6501-4	
<b>GENERAL SPECIFICATIONS</b>		
Nominal Diameter:	6.5 inch	
Rated Impedance:	4 ohms	
Operating Bandwidth:	60-5k Hz (-3dB)	
Power Handling Capacity:	50 Watts	
Sensitivity (1W/M):	90 dB(+3dB)	
Voice Coil Diameter:	1 inch	
<b>THIELE-SMALL PARAMETERS</b>		
Resonance Frequency	Fs:	66.18 HZ
DC Resistance	Re:	3.6ohm
Mechanical Q Factor	Qms:	3,28
Electrical Q Factor	Qes:	0,74
Total Q Factor	Qts:	0,61
Equivalent Gas air load	Vas:	14.55 L
Surface Area of Cone	Sd:	0.0139 m <sup>2</sup>
Efficiency Bandwidth Product	EBP	81,6
Voice Coil Over Hang	X-max	3 mm
<b>PHYSICAL INFORMATION</b>		
Basket:	Black Stamp Steel	
Magnet Type:	10 OZ	
Cone Material:	Paper	
Surround:	Foam	
Dust Cap:	Paper	
Damper:	cloth	

  

CH A Ohm Resolution 1/6 Octave Unsmoothed Delay (ms) 0.000 Dist: Rise (dB) 30.00

CH A dB SPL 1/6 Octave 4894Hz 16K Rectangular Start: 0.00ms Stop: 341.31ms Freq: 0.253Hz Length: 341.31ms

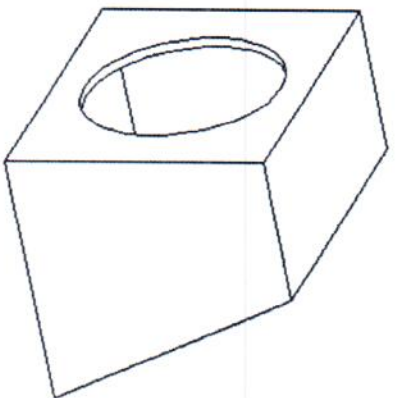
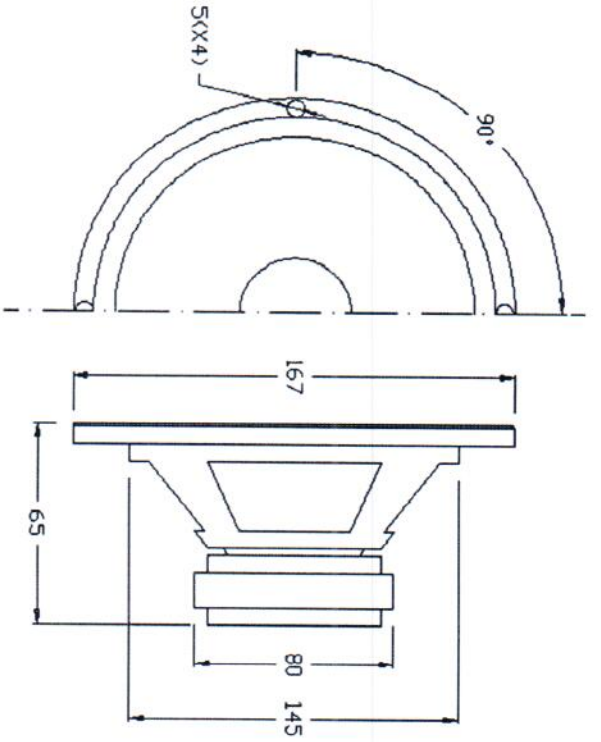

**Sealed Box**

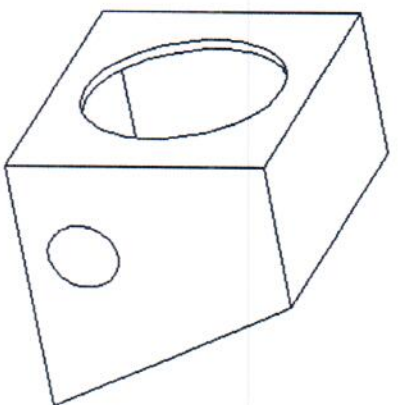

**Vented Box**

Suggested enclosure parameters	Sealed		Vented	
	Small	Large	Small	Large
Enclosure volume, cu. ft.	0,5	NA	0,5	NA
Vent length, inches	-	-	5,5	-
Vent diameter, inches	-	-	2,3	-
Enclosure Frequency, Hz	90	-	-	-
Fb Tuning Frequency of Vented Enclosure, Hz	NA	-	58	-
F3 Systems 3dB Down Piont (Sealed), Hz	67, 5	-	-	-