



## SPEAKER SPECIFICATIONS

<b>Model Number:</b>	G4001-8	
<b>GENERAL SPECIFICATIONS</b>		
Nominal Diameter:	4 inch	
Rated Impedance:	8 ohms	
Operating Bandwidth:	800-10k hz (-3dB)	
Power Handling Capacity:	25 Watts	
Sensitivity (1W/M):	90 dB(+3dB)	
Voice Coil Diameter:	0.75 inch	
<b>THIELF-SMALL PARAMETERS</b>		
Resonance Frequency	Fs:	-
DC Resistance	Re:	-
Mechanical Q Factor	Qms:	-
Electrical Q Factor	Qes:	-
Total Q Factor	Qts:	-
Equivalent Gas air load	Vas:	-
Surface Area of Cone	Sd:	-
Efficiency Bandwidth Product	EBP	-
Voice Coil Over Hang	X-max	1.5 mm
<b>PHYSICAL INFORMATION</b>		
Basket:	Black Stamp Steel	
Magnet Type:	10 OZ	
Cone Material:	Paper	
Surround:	Rubber	
Dust Cap:	pp	
Damper:	cloth	

  

CH A Ohm Resolution 1/6 Octave Unsmoothed Delay [ms] 0.000 Dist Rise [dB] 30.00

CH A dB SPL 1/6 Octave 48kHz 16k Rectangular Start 0.00ms Stop 341.3ms Freq. O 2.93Hz Length 341.3ms

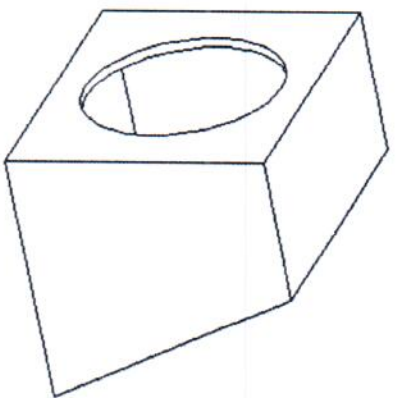
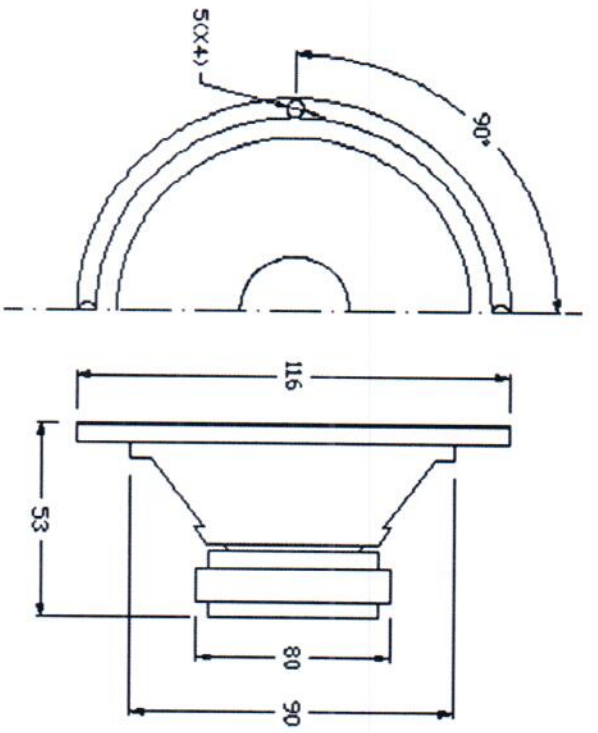

**Sealed Box**

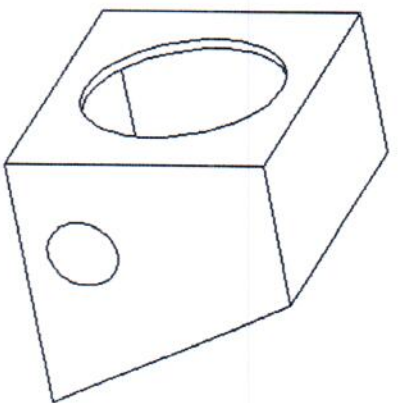

**Vented Box**

Suggested enclosure parameters	Sealed		Vented	
	Small	Large	Small	Large
Enclosure volume, cu. ft.	0, 25	NA	-	NA
Vent length, inches	-	-	-	-
Vent diameter, inches	-	-	-	-
Enclosure Frequency, Hz	1000	-	-	-
Fb Tuning Frequency of Vented Enclosure, Hz	NA	-	-	-
F3 Systems 3dB Down Piont (Sealed), Hz	-	-	-	-