



SPEAKER SPECIFICATIONS

Model Number:	G4001-4	
GENERAL SPECIFICATIONS		
Nominal Diameter:	4 inch	
Rated Impedance:	4 ohms	
Operating Bandwidth:	800-10k Hz (-3dB)	
Power Handling Capacity:	25 Watts	
Sensitivity (1W/M):	90 dB(+/-3dB)	
Voice Coil Diameter:	0.75 inch	
THIELE-SMALL PARAMETERS		
Resonance Frequency	Fs:	-
DC Resistance	Re:	-
Mechanical Q Factor	Qms:	-
Electrical Q Factor	Qes:	-
Total Q Factor	Qts:	-
Equivalent Gas air load	Vas:	-
Surface Area of Cone	Sd:	-
Efficiency Bandwidth Product	EBP	-
Voice Coil Over Hang	X-max	1.5 mm
PHYSICAL INFORMATION		
Basket:	Black Stamp Steel	
Magnet Type:	10 OZ	
Cone Material:	Paper	
Surround:	Rubber	
Dust Cap:	pp	
Damper:	cloth	

CH A Ohm Resolution 1/6 Octave Unsmoothed Delay [ms] 0.000 Dist Rise [dB] 30.00

CH A dB SPL 1/6 Octave 48Hz 16k Rectangular Start 0.00ms Stop 341.31ms Freq. 0.293Hz Length 341.31ms

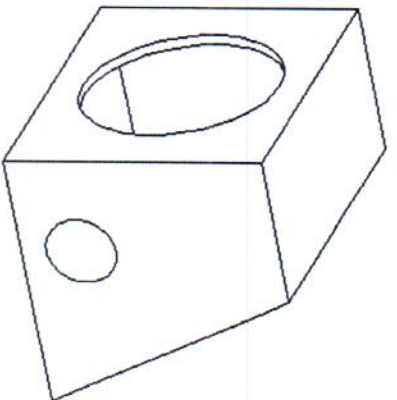
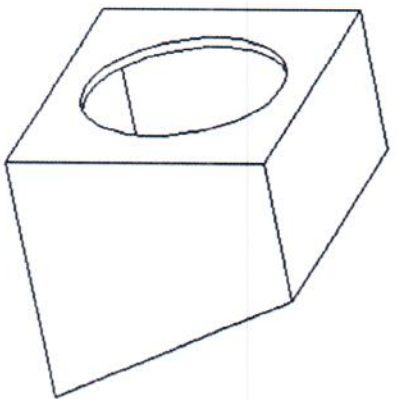
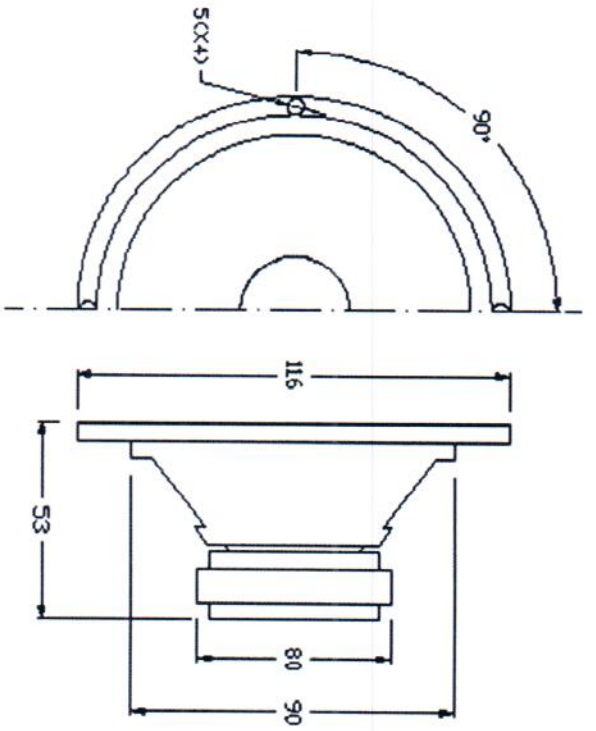

Sealed Box

Vented Box

Suggested enclosure parameters	Sealed		Vented	
	Small	Large	Small	Large
Enclosure volume, cu. ft.	0, 25	NA	-	NA
Vent length, inches	-	-	-	-
Vent diameter, inches	-	-	-	-
Enclosure Frequency, Hz	1000	-	-	-
Fb Tuning Frequency of Vented Enclosure, Hz	NA	-	-	-
F3 Systems 3dB Down Point (Sealed), Hz	-	-	-	-