

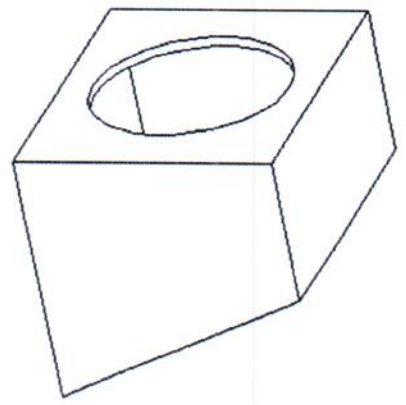

SPEAKER SPECIFICATIONS

Model Number:	G1501-8	
GENERAL SPECIFICATIONS		
Nominal Diameter:	15 inch	
Rated Impedance:	8 ohms	
Operating Bandwidth:	20-3k hz (-6dB)	
Power Handling Capacity:	200 Watts	
Sensitivity (1W/M) :	91 dB(+/-3dB)	
Voice Coil Diameter:	2 inch	
THIELF-SMALL PARAMETERS		
Resonance Frequency	Fs:	29.79 HZ
DC Resistance	Re:	7.2ohm
Mechanical Q Factor	Qms:	2.73
Electrical Q Factor	Qes:	1
Total Q Factor	Qts:	0.73
Equivalent Gas air load	Vas:	268 L
Surface Area of Cone	Sd:	0.0855 m ²
Efficiency Bandwidth Product	EBP	30
Voice Coil Over Hang	X-max	5 mm
PHYSICAL INFORMATION		
Basket:	Black Stamp Steel	
Magnet Type:	40 OZ	
Cone Material:	Paper	
Surround:	Rubber	
Dust Cap:	Paper	
Damper:	cloth	

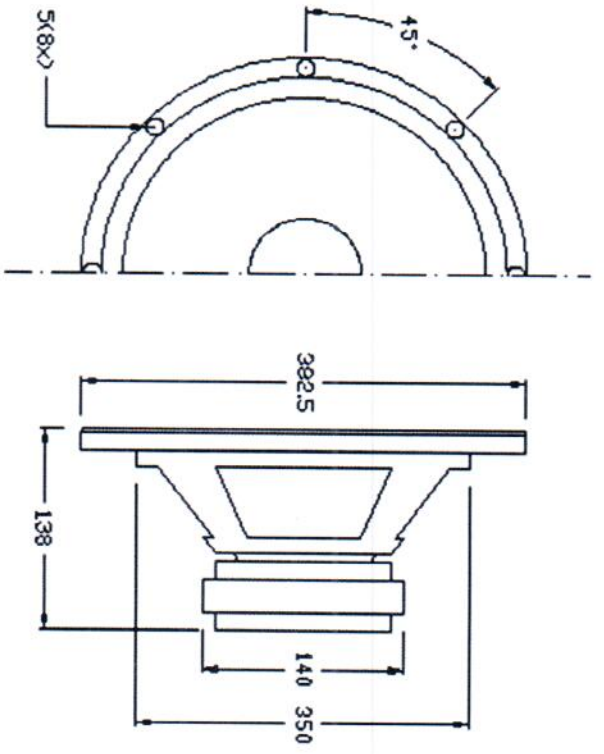

Sealed Box

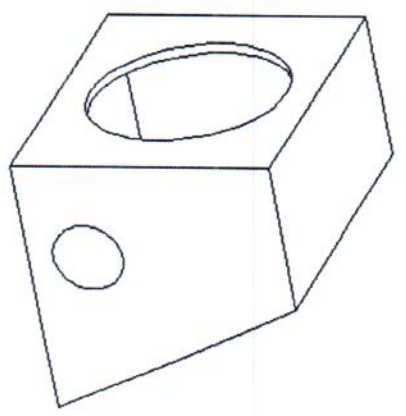

Vented Box

Suggested enclosure parameters	Sealed		Vented	
	Small	Large	Small	Large
Enclosure volume, cu. ft.	2	NA	2, 0	NA
Vent length, inches	-	-	9, 0	-
Vent diameter, inches	-	-	6, 0	-
Enclosure Frequency, Hz	70	-	-	-
Fb Tuning Frequency of Vented Enclosure, Hz	NA	-	50	-
F3 Systems 3dB Down Point (Sealed), Hz	52	-	-	-