

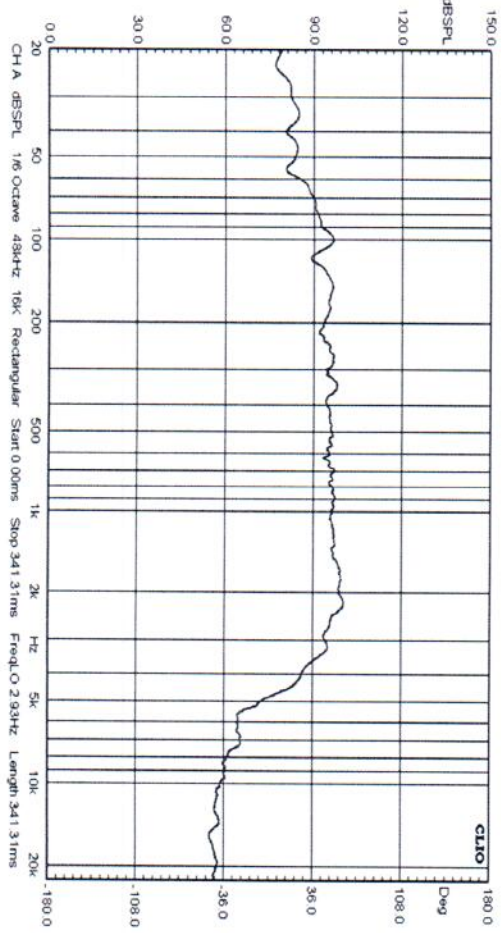

SPEAKER SPECIFICATIONS

Model Number:	G1201-4
GENERAL SPECIFICATIONS	
Nominal Diameter:	12 inch
Rated Impedance:	4 ohms
Operating Bandwidth:	30-4k hz (-3dB)
Power Handling Capacity:	140 Watts
Sensitivity (1W/M):	91 dB(+3dB)
Voice Coil Diameter:	1.5 inch
THIELE-SMALL PARAMETERS	
Resonance Frequency	Fs: 41.65 HZ
DC Resistance	Re: 3.6ohm
Mechanical Q Factor	Qms: 3, 39
Electrical Q Factor	Qes: 0, 93
Total Q Factor	Qts: 0, 73
Equivalent Gas air load	Vas: 40.8 L
Surface Area of Cone	Sd: 0.0523 m ²
Efficiency Bandwidth Product	EBP 44, 4
Voice Coil Over Hang	X-max 5 mm
PHYSICAL INFORMATION	
Basket:	Black Stamp Steel
Magnet Type:	30 OZ
Cone Material:	Paper
Surround:	Foam
Dust Cap:	Paper
Damper:	cloth

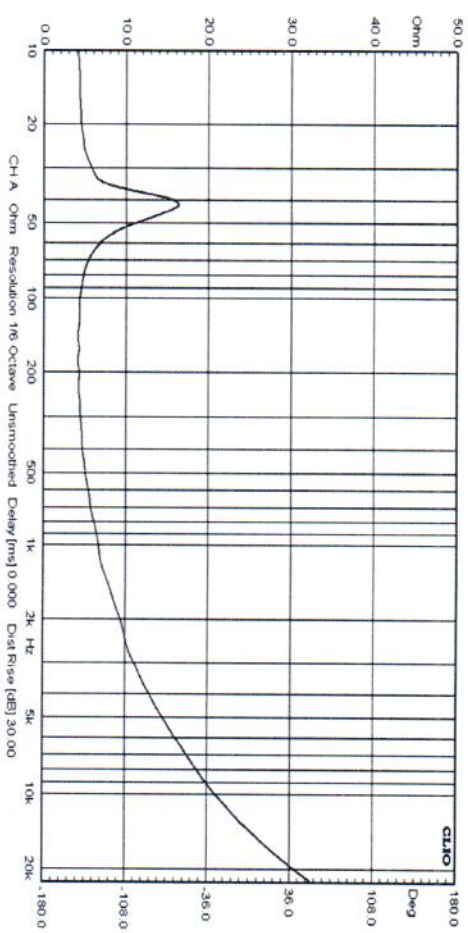

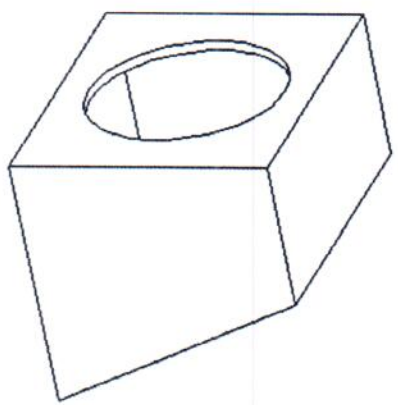
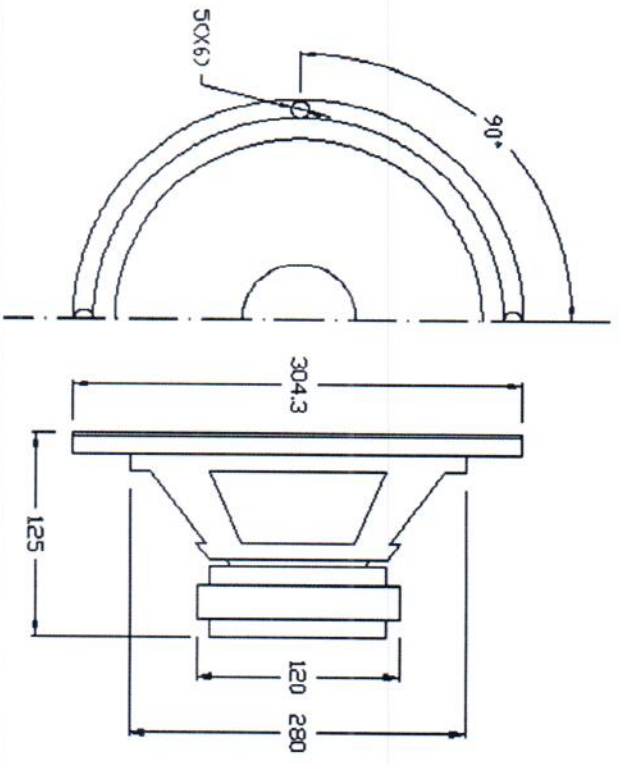

Sealed Box

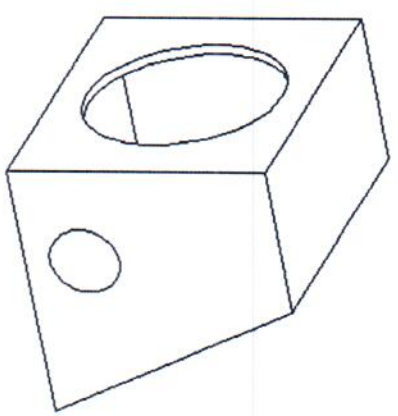

Vented Box

Suggested enclosure parameters	Sealed		Vented	
	Small	Large	Small	Large
Enclosure volume, cu. ft.	1, 2	NA	1, 5	NA
Vent length, inches	-	-	6, 0	-
Vent diameter, inches	-	-	3, 5	-
Enclosure Frequency, Hz	66	-	-	-
Fb Tuning Frequency of Vented Enclosure, Hz	NA	-	50	-
F3 Systems 3dB Down Point(Sealed), Hz	49, 5	-	-	-