

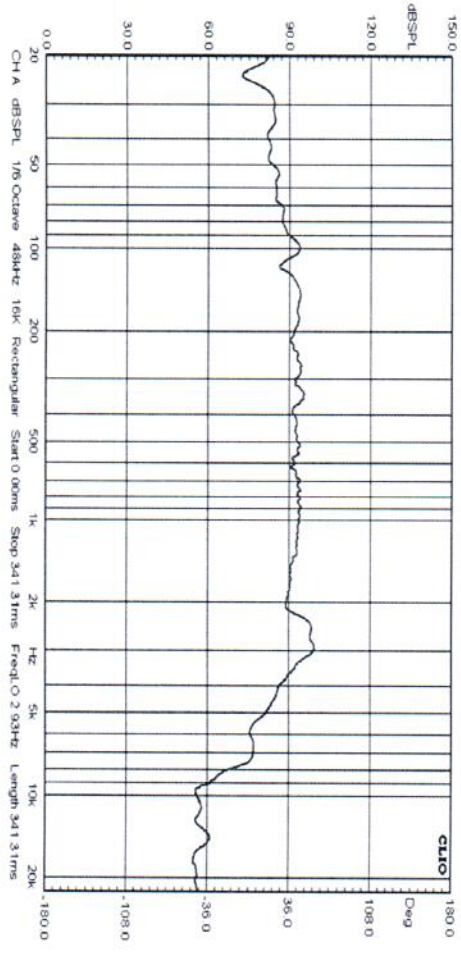

SPEAKER SPECIFICATIONS

Model Number:	B1002-8
GENERAL SPECIFICATIONS	
Nominal Diameter:	10 inch
Rated Impedance:	8 ohms
Operating Bandwidth:	40-1k Hz (-3dB)
Power Handling Capacity:	110 Watts
Sensitivity (1W/M) :	91 dB(+/-3dB)
Voice Coil Diameter:	1.5 inch
THIELE-SMALL PARAMETERS	
Resonance Frequency	Fs: 45.25 HZ
DC Resistance	Re: 7.2ohm
Mechanical Q Factor	Qms: 3.54
Electrical Q Factor	Qes: 1.27
Total Q Factor	Qts: 0.93
Equivalent Gas air load	Vas: 67.68 L
Surface Area of Cone	Sd: 0.0346 m ²
Efficiency Bandwidth Product	EBP 35, 6
Voice Coil Over Hang	X-max 5 mm
PHYSICAL INFORMATION	
Basket:	Black Stamp Steel
Magnet Type:	24 OZ
Cone Material:	Paper
Surround:	Foam
Dust Cap:	Paper
Damper:	cloth

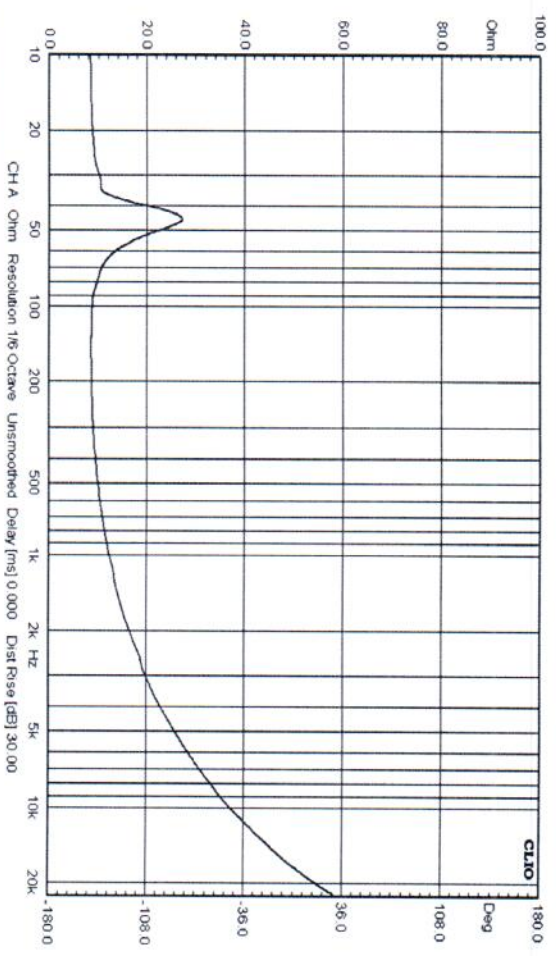

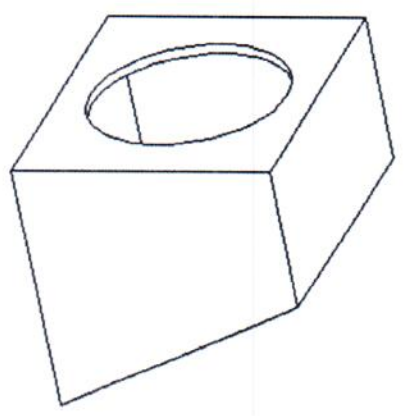
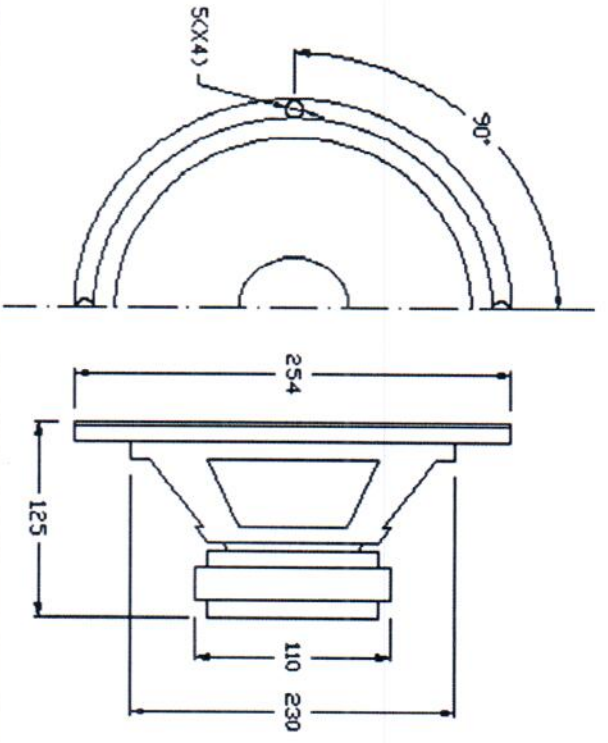

Sealed Box

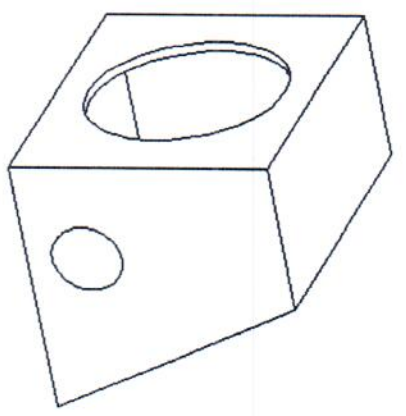

Vented Box

Suggested enclosure parameters	Sealed		Vented	
	Small	Large	Small	Large
Enclosure volume, cu. ft.	1, 2	NA	1, 2	NA
Vent length, inches	-	-	5, 2	-
Vent diameter, inches	-	-	3, 0	-
Enclosure Frequency, Hz	55	-	-	-
Fb Tuning Frequency of Vented Enclosure, Hz	NA	-	50	-
F3 Systems 3dB Down Point (Sealed), Hz	42	-	-	-