



SPEAKER SPECIFICATIONS

| | | | |
|--------------------------------|-------------------|-----------------------|--|
| Model Number: | G1002-4 | | |
| GENERAL SPECIFICATIONS | | | |
| Nominal Diameter: | 10 inch | | |
| Rated Impedance: | 4 ohms | | |
| Operating Bandwidth: | 40-1k Hz (-3dB) | | |
| Power Handling Capacity: | 110 Watts | | |
| Sensitivity (1W/M): | 91 dB(+/-3dB) | | |
| Voice Coil Diameter: | 1.5 inch | | |
| THIELE-SMALL PARAMETERS | | | |
| Resonance Frequency | Fs: | 41.65 HZ | |
| DC Resistance | Re: | 3.6ohm | |
| Mechanical Q Factor | Qms: | 3, 77 | |
| Electrical Q Factor | Qes: | 1, 23 | |
| Total Q Factor | Qts: | 0, 93 | |
| Equivalent Gas air load | Vas: | 64.8 L | |
| Surface Area of Cone | Sd: | 0.0346 m ² | |
| Efficiency Bandwidth Product | EBP | 33, 86 | |
| Voice Coil Over Hang | X-max | 5 mm | |
| PHYSICAL INFORMATION | | | |
| Basket: | Black Stamp Steel | | |
| Magnet Type: | 24 OZ | | |
| Cone Material: | Paper | | |
| Surround: | Foam | | |
| Dust Cap: | Paper | | |
| Damper: | cloth | | |

CH A Ohm Resolution 1/6 Octave Unsmoothed Delay [ms] 0.000 Dist Rise [dB] 30.00

CH A dB SPL 1/6 Octave 48Hz 10k Rectangular Start 0.00ms Stop 341.31ms Freq: 0.293Hz Length 341.31ms

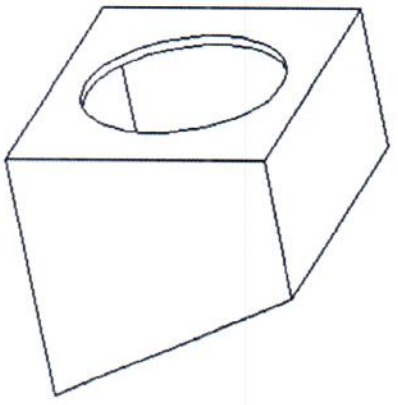
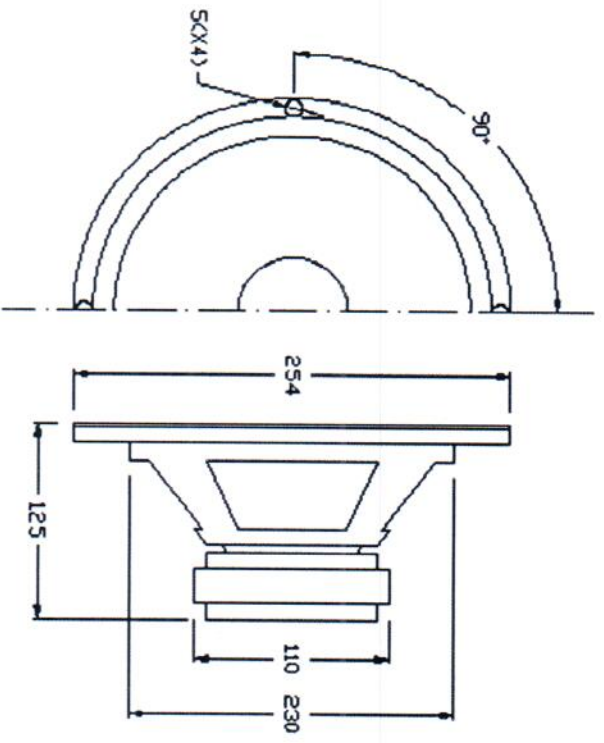

Sealed Box

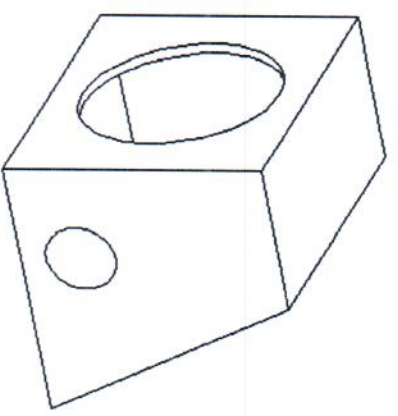

Vented Box

| Suggested enclosure parameters | Sealed | | Vented | |
|---|--------|-------|--------|-------|
| | Small | Large | Small | Large |
| Enclosure volume, cu. ft. | 1, 2 | NA | 1, 2 | NA |
| Vent length, inches | - | - | 5, 2 | - |
| Vent diameter, inches | - | - | 3, 0 | - |
| Enclosure Frequency, Hz | 55 | - | - | - |
| Fb Tuning Frequency of Vented Enclosure, Hz | NA | - | 50 | - |
| F3 Systems 3dB Down Point (Sealed), Hz | 42 | - | - | - |