

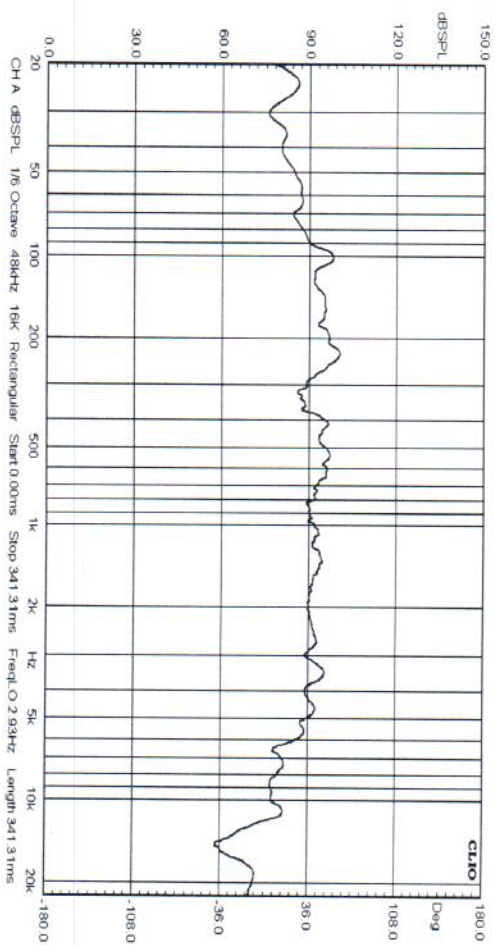

SPEAKER SPECIFICATIONS

Model Number:	C8005-8	
GENERAL SPECIFICATIONS		
Nominal Diameter:	8 inch	
Rated Impedance:	8 ohms	
Operating Bandwidth:	40-5k hz (-3dB)	
Power Handling Capacity:	150 Watts	
Sensitivity (1W/M):	91 dB(+/-3dB)	
Voice Coil Diameter:	1.5 inch	
THIELE-SMALL PARAMETERS		
Resonance Frequency	Fs:	52.3 HZ
DC Resistance	Re:	6.8ohm
Mechanical Q Factor	Qms:	3, 1
Electrical Q Factor	Qes:	1, 13
Total Q Factor	Qts:	0, 83
Equivalent Gas air load	Vas:	21.25 L
Surface Area of Cone	Sd:	0.0219 m ²
Efficiency Bandwidth Product	EBP	46, 2
Voice Coil Over Hang	X-max	5 mm
PHYSICAL INFORMATION		
Basket:	Chrome Stamp Steel	
Magnet Type:	24 OZ	
Cone Material:	Injection PP	
Surround:	Rubber	
Dust Cap:	Injection PP	
Damper:	cloth	

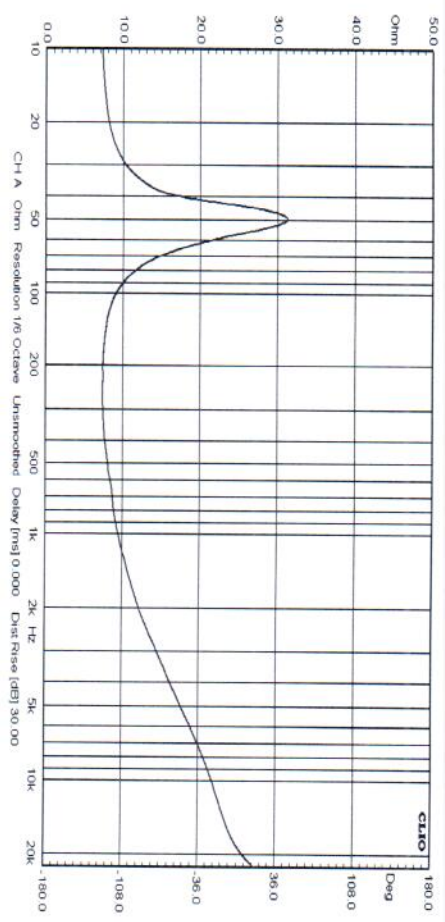

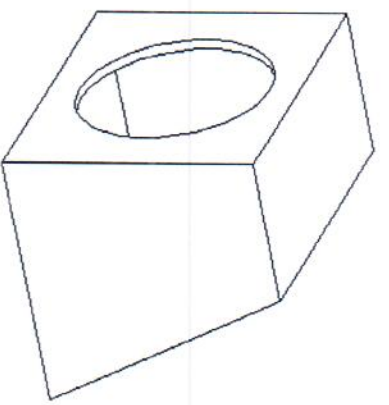
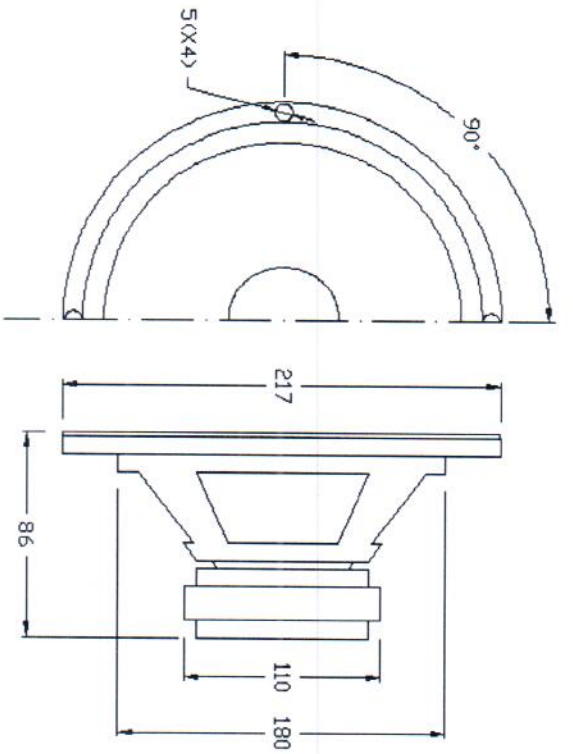

Sealed Box

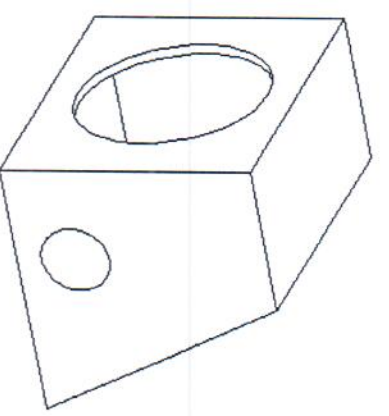

Vented Box

Suggested enclosure parameters	Sealed		Vented	
	Small	Large	Small	Large
Enclosure volume, cu. ft.	0,7	NA	0,7	NA
Vent length, inches	-	-	6,0	-
Vent diameter, inches	-	-	2,7	-
Enclosure Frequency, Hz	72	-	-	-
Fb Tuning Frequency of Vented Enclosure, Hz	NA	-	54	-
F3 Systems 3dB Down Point (Sealed), Hz	58	-	-	-