



SPEAKER SPECIFICATIONS

| | | |
|--------------------------------|-------------------|-----------------------|
| Model Number: | C8004-4 | |
| GENERAL SPECIFICATIONS | | |
| Nominal Diameter: | 8 inch | |
| Rated Impedance: | 4 ohms | |
| Operating Bandwidth: | 40-5k Hz (-3dB) | |
| Power Handling Capacity: | 150 Watts | |
| Sensitivity (1W/M): | 91 dB(+/-3dB) | |
| Voice Coil Diameter: | 1.5 inch | |
| THIELE-SMALL PARAMETERS | | |
| Resonance Frequency | Fs: | 45.32 HZ |
| DC Resistance | Re: | 3.4ohm |
| Mechanical Q Factor | Qms: | 3,27 |
| Electrical Q Factor | Qes: | 0,88 |
| Total Q Factor | Qts: | 0,69 |
| Equivalent Gas air load | Vas: | 28.33 L |
| Surface Area of Cone | Sd: | 0.0214 m ² |
| Efficiency Bandwidth Product | EBP | 51,5 |
| Voice Coil Over Hang | X-max | 5 mm |
| PHYSICAL INFORMATION | | |
| Basket: | Black Stamp Steel | |
| Magnet Type: | 24 OZ | |
| Cone Material: | Paper | |
| Surround: | Rubber | |
| Dust Cap: | PP | |
| Damper: | cloth | |

CH A Ohm Resolution 1/8 Octave Unsmoothed Delay [ms] 0.000 Dist Rise [dB] 30.00

CH A dB SPL 1/6 Octave 48k-Hz 16K Rectangular Start 0.00ms Stop 341.31ms Freq. 0.293Hz Length 341.31ms

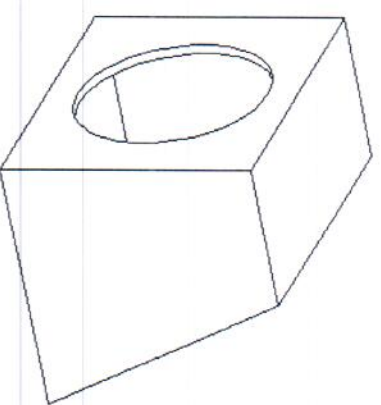
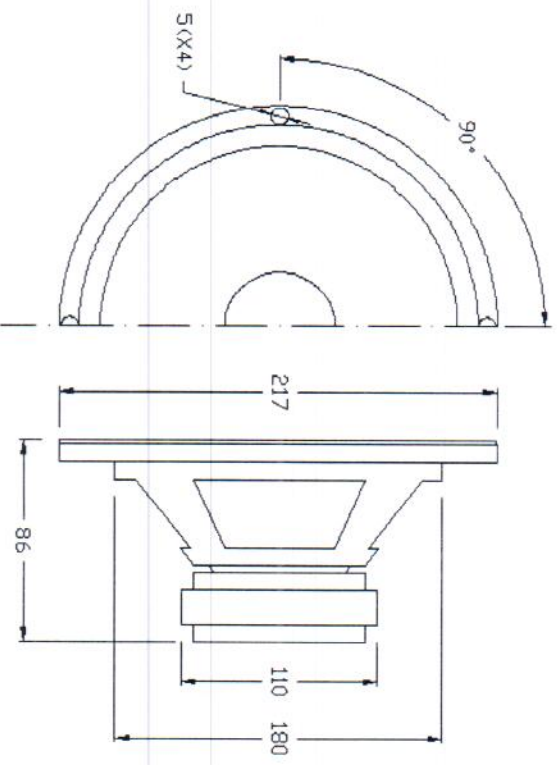

Sealed Box

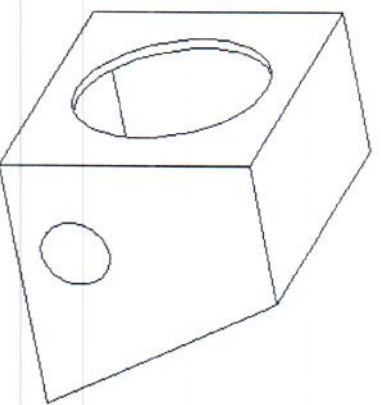

Vented Box

| Suggested enclosure parameters | Sealed | | Vented | |
|---|--------|-------|--------|-------|
| | Small | Large | Small | Large |
| Enclosure volume, cu. ft. | 0,7 | NA | 0,7 | NA |
| Vent length, inches | - | - | 6,0 | - |
| Vent diameter, inches | - | - | 2,7 | - |
| Enclosure Frequency, Hz | 68 | - | - | - |
| Fb Tuning Frequency of Vented Enclosure, Hz | NA | - | 50 | - |
| F3 Systems 3dB Down Piont (Sealed), Hz | 52 | - | - | - |