

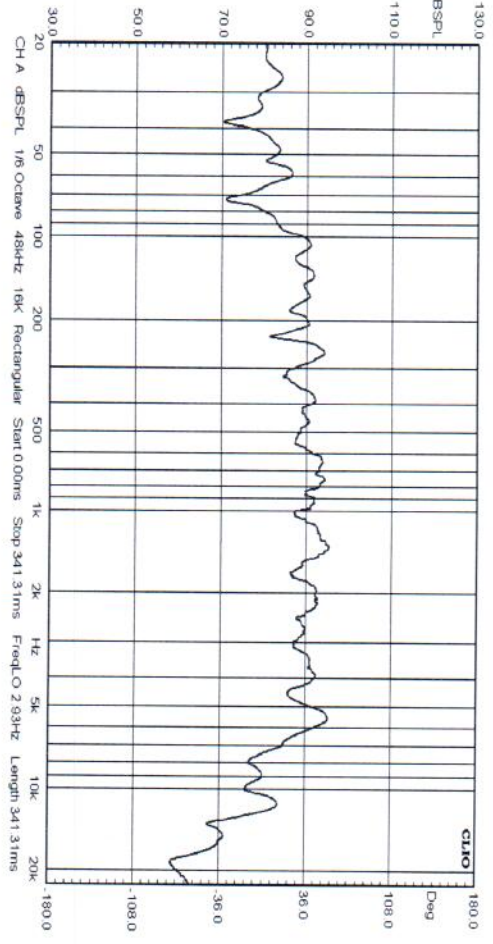

SPEAKER SPECIFICATIONS

Model Number:	C6504-8	
GENERAL SPECIFICATIONS		
Nominal Diameter:	6.5 inch	
Rated Impedance:	8 ohms	
Operating Bandwidth:	50-6k hz (-3dB)	
Power Handling Capacity:	125 Watts	
Sensitivity (1W/M):	90 dB(+3dB)	
Voice Coil Diameter:	1 inch	
THIELE-SMALL PARAMETERS		
Resonance Frequency	Fs:	55.87 HZ
DC Resistance	Re:	7.2ohm
Mechanical Q Factor	Qms:	2, 09
Electrical Q Factor	Qes:	0, 77
Total Q Factor	Qts:	0, 56
Equivalent Gas air load	Vas:	23.77 L
Surface Area of Cone	Sd:	0.0139 m2
Efficiency Bandwidth Product	EBP	72, 55
Voice Coil Over Hang	X-max	3 mm
PHYSICAL INFORMATION		
Basket:	Black Stamp Steel	
Magnet Type:	20 OZ	
Cone Material:	Paper	
Surround:	Rubber	
Dust Cap:	PP	
Damper:	cloth	

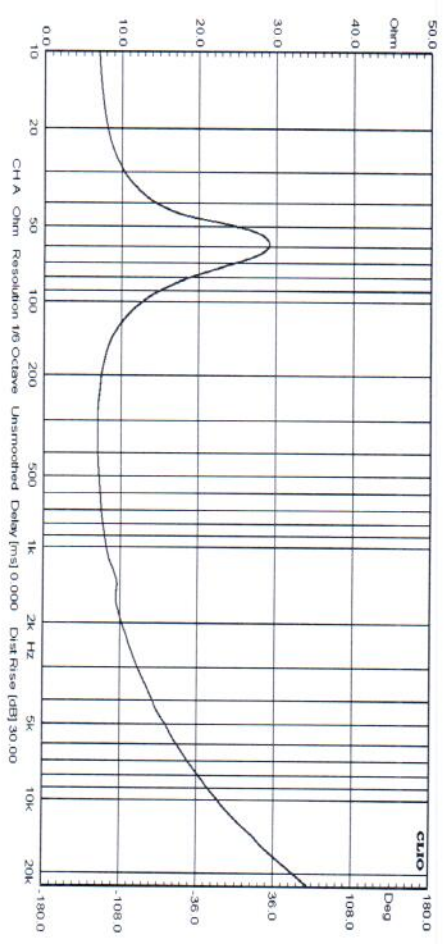

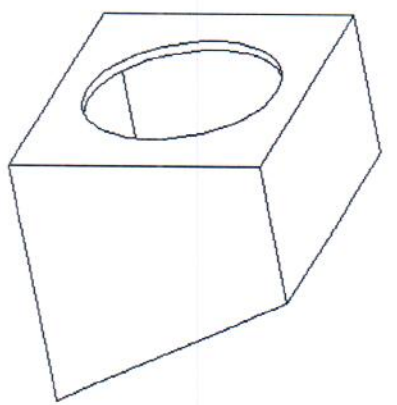
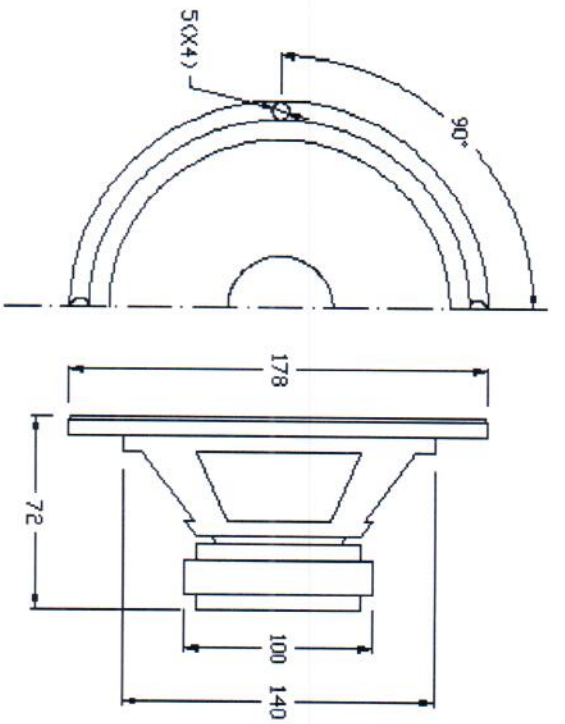

Sealed Box

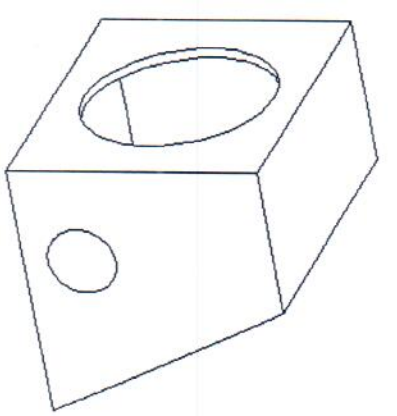

Vented Box

Suggested enclosure parameters	Sealed		Vented	
	Small	Large	Small	Large
Enclosure volume, cu. ft.	0, 5	NA	0, 5	NA
Vent length, inches	-	-	5, 5	-
Vent diameter, inches	-	-	2, 3	-
Enclosure Frequency, Hz	76	-	-	-
Fb Tuning Frequency of Vented Enclosure, Hz	NA	-	55	-
F3 Systems 3dB Down Point(Sealed), Hz	60	-	-	-