

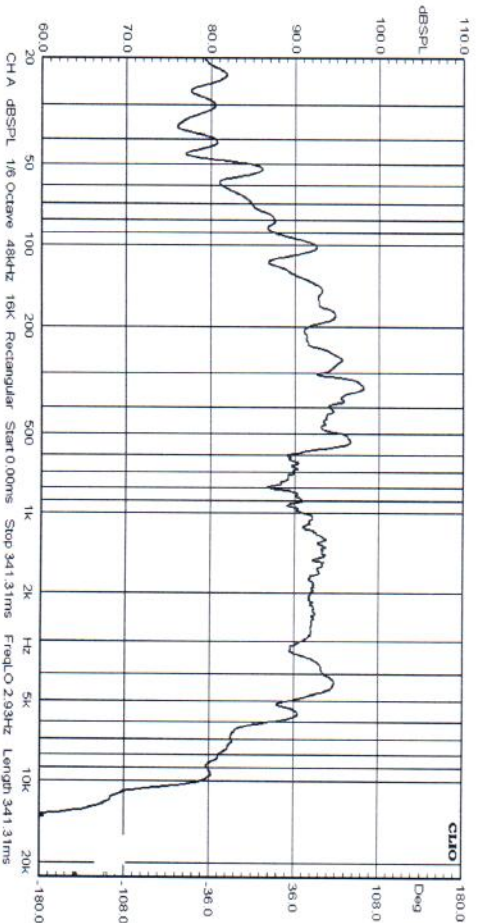

SPEAKER SPECIFICATIONS

Model Number:	B8023-8
GENERAL SPECIFICATIONS	
Nominal Diameter:	8 inch
Rated Impedance:	8 ohms
Operating Bandwidth:	35-5k hz (-3dB)
Power Handling Capacity:	200 Watts
Sensitivity (1W/M):	91 dB(+3dB)
Voice Coil Diameter:	1.5 inch
THIELE-SMALL PARAMETERS	
Resonance Frequency	Fs: 36 HZ
DC Resistance	Re: 6.8ohm
Mechanical Q Factor	Qms: 2, 3
Electrical Q Factor	Qes: 0, 3411
Total Q Factor	Qts: 0, 297
Equivalent Gas air load	Vas: 55 L
Surface Area of Cone	Sd: 0.0219 m ²
Efficiency Bandwidth Product	EBP 105, 5
Voice Coil Over Hang	X-max 5 mm
PHYSICAL INFORMATION	
Basket:	Black Stamp Steel
Magnet Type:	30 OZ
Cone Material:	PP
Surround:	Rubber
Dust Cap:	PP
Damper:	cloth

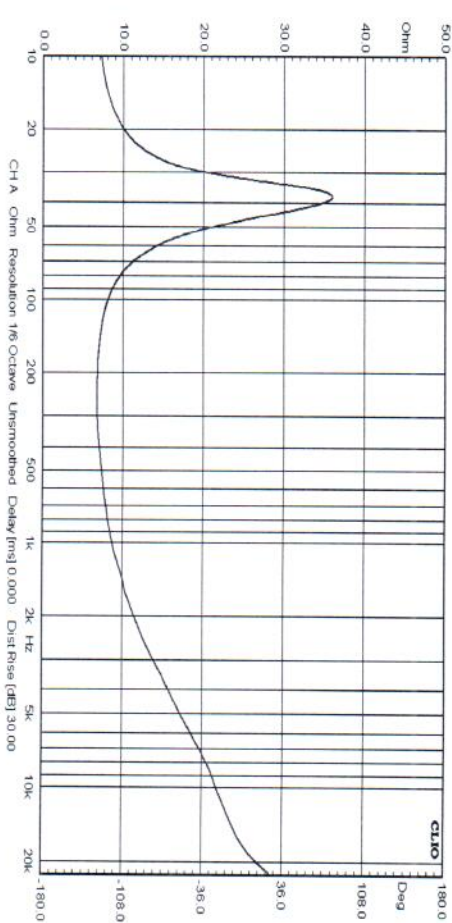

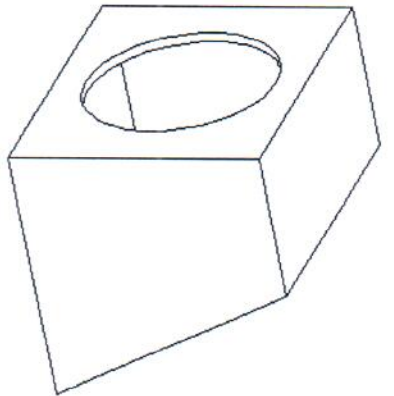
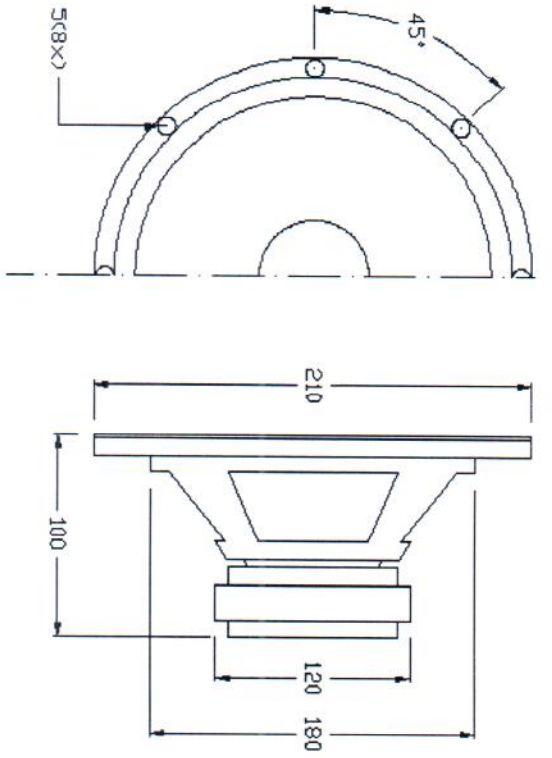

Sealed Box

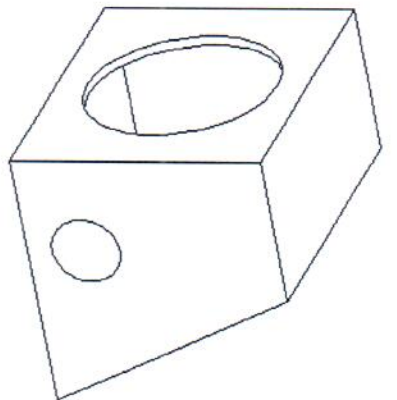

Vented Box

Suggested enclosure parameters	Sealed		Vented	
	Small	Large	Small	Large
Enclosure volume, cu. ft.	0,7	NA	0,7	NA
Vent length, inches	-	-	6,0	-
Vent diameter, inches	-	-	2,7	-
Enclosure Frequency, Hz	66	-	-	-
Fb Tuning Frequency of Vented Enclosure, Hz	NA	-	50	-
F3 Systems 3dB Down Piont (Sealed), Hz	49	-	-	-