

POWERED BY

QUER®

# BLOCKS

ZAB0107



**RC**  
RADIO CONTROL

## Model B

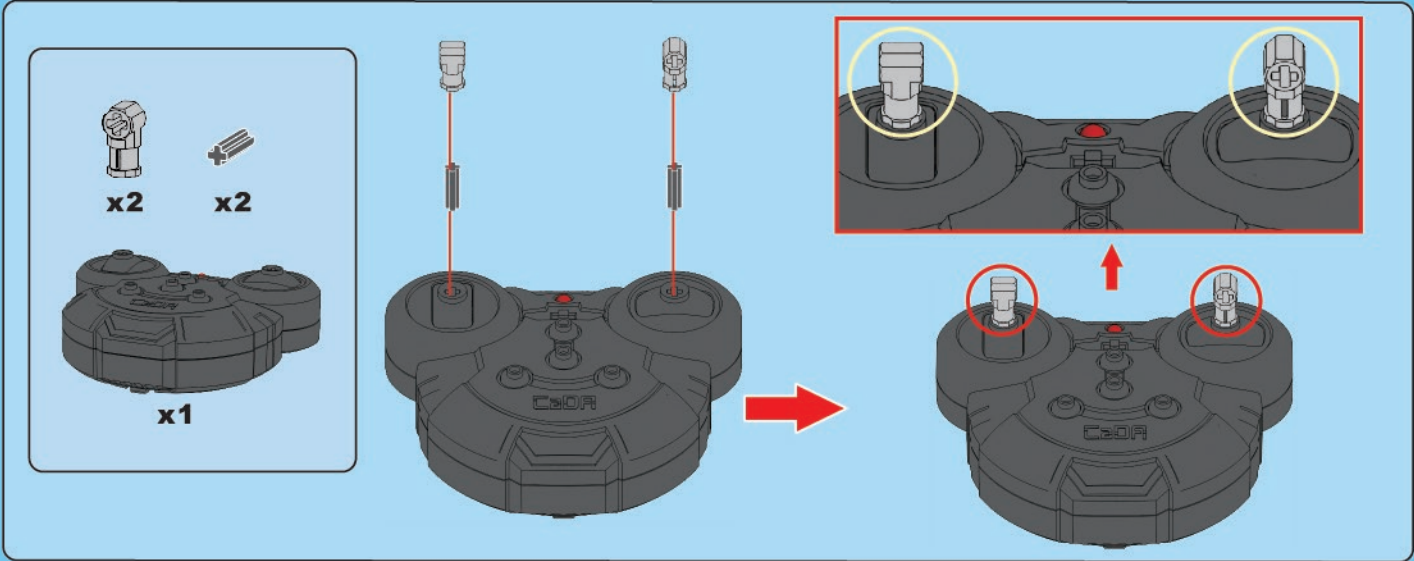
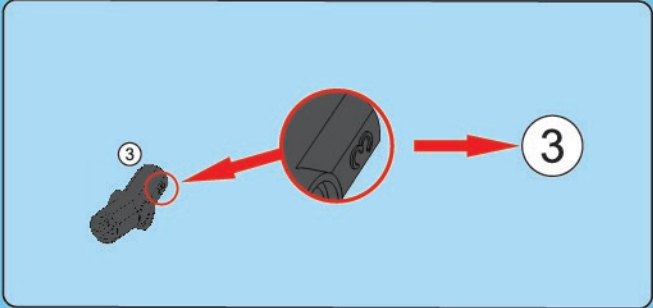
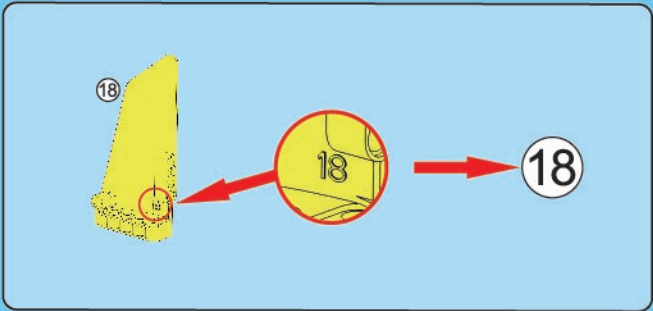
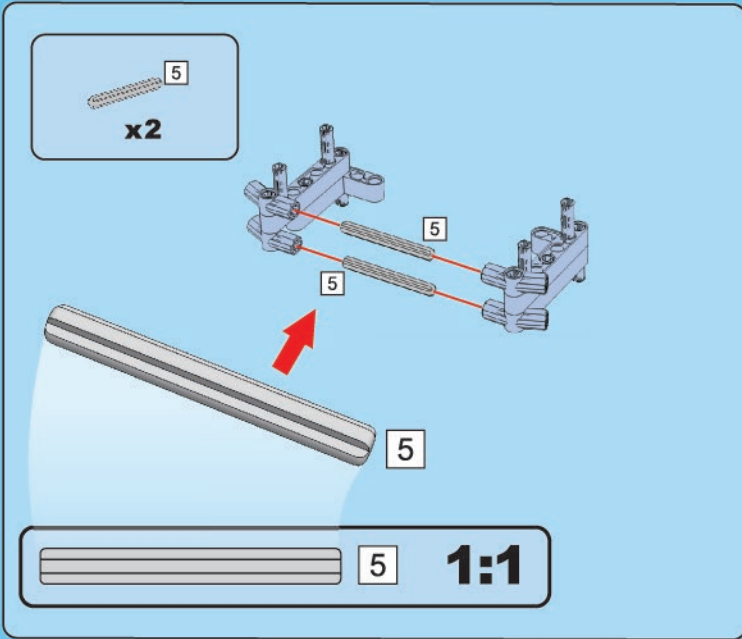

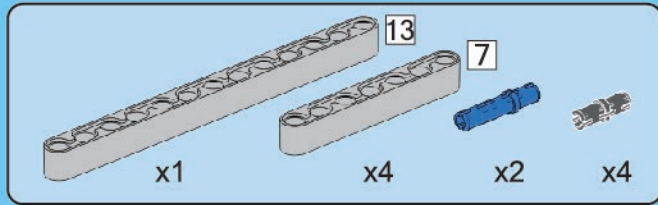
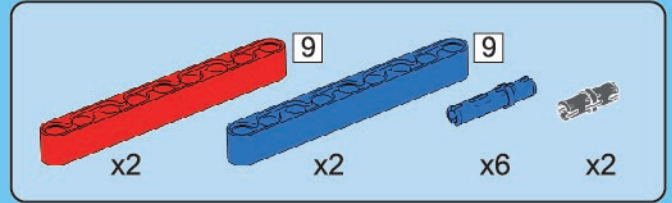
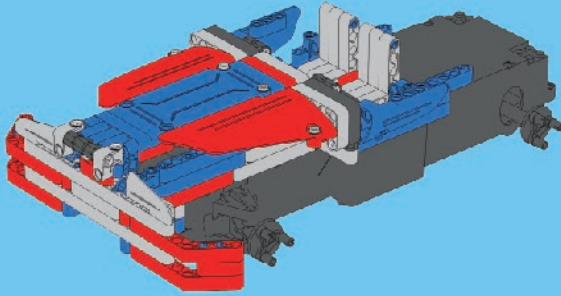
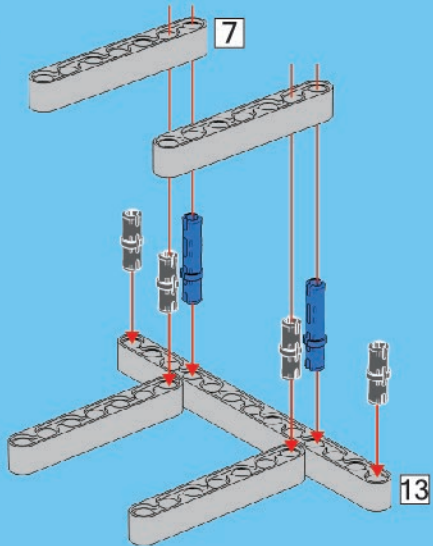
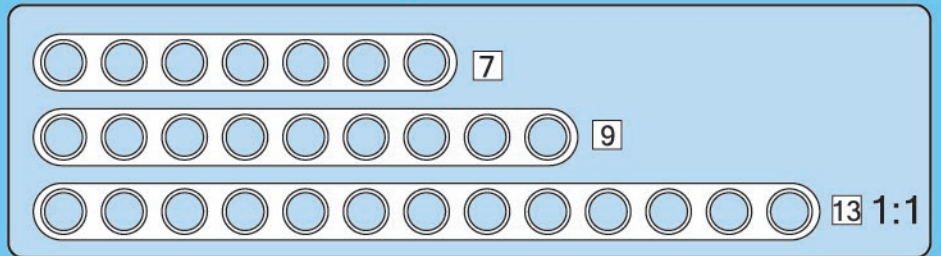
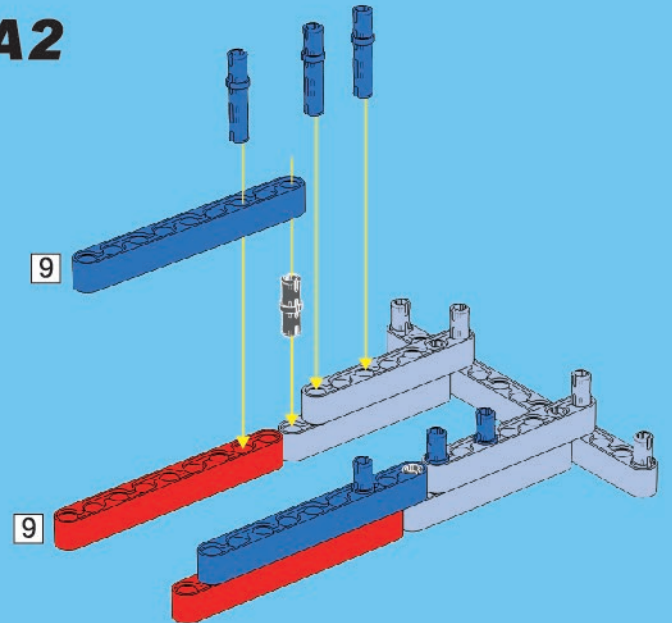
**A****A1****A2**

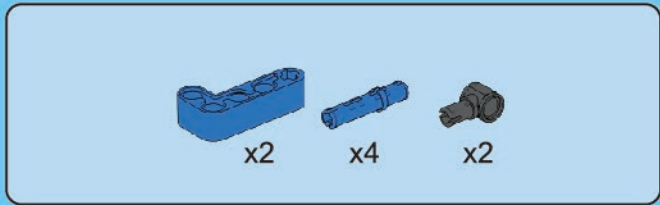

# A3

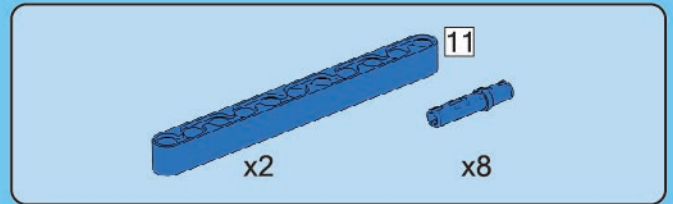
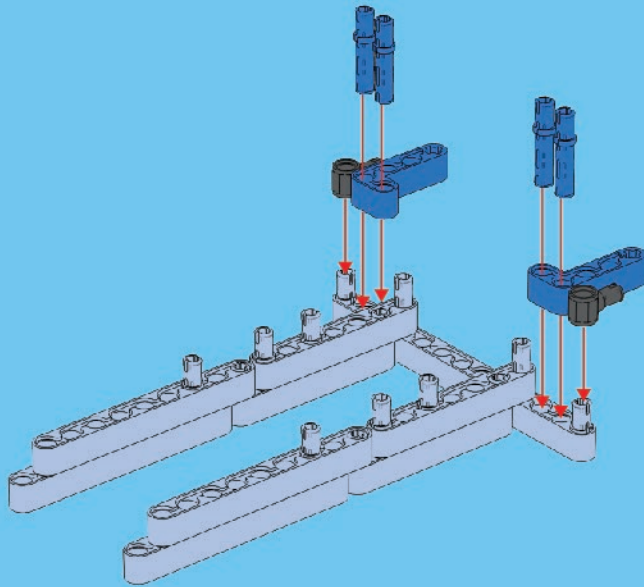

# A4

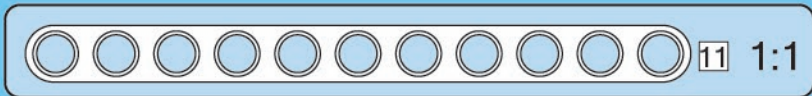
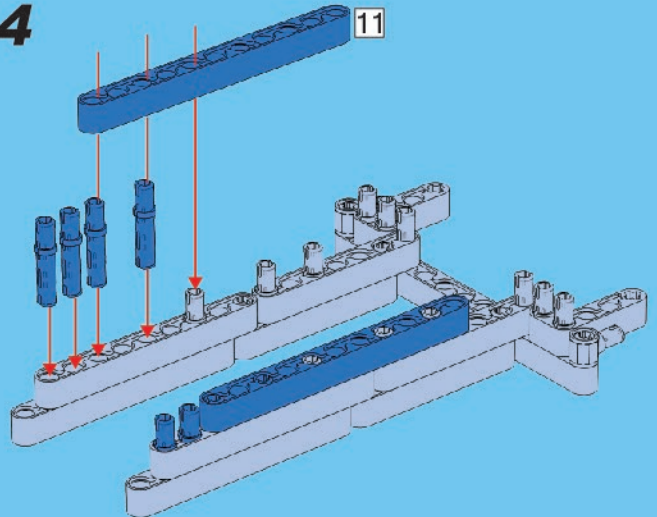

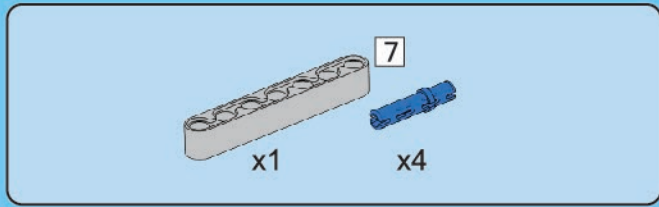

**A5**

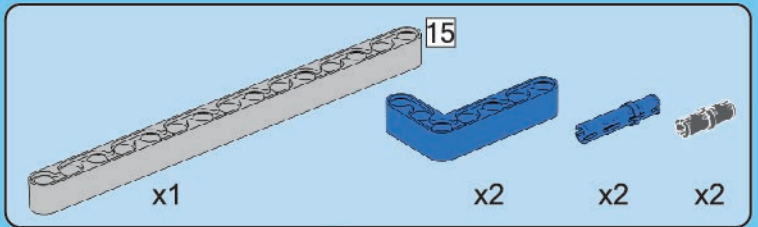
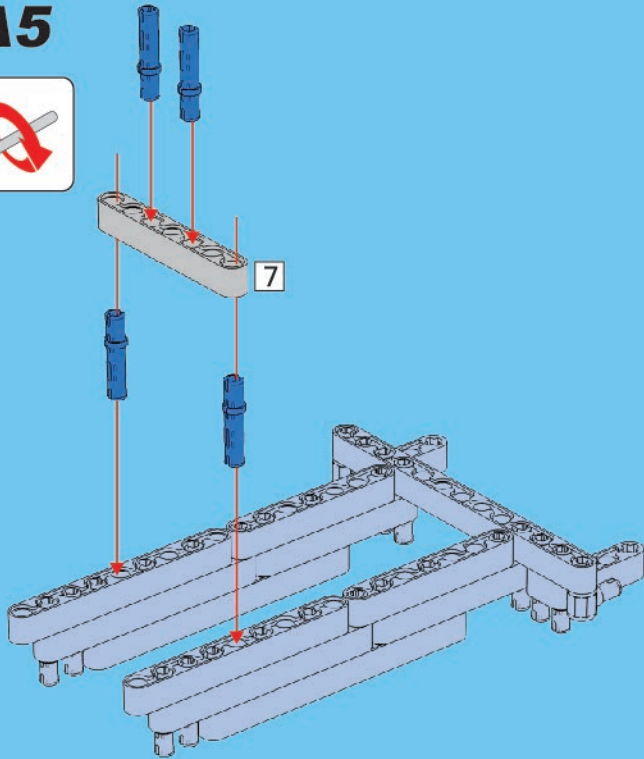

**A6**

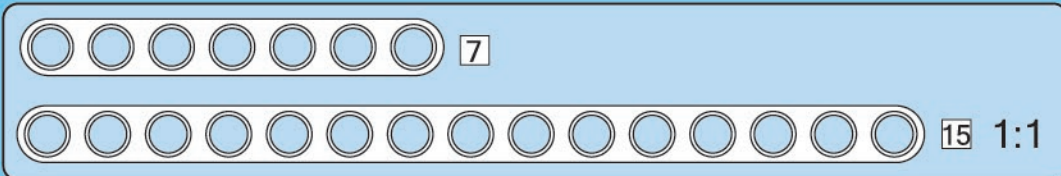
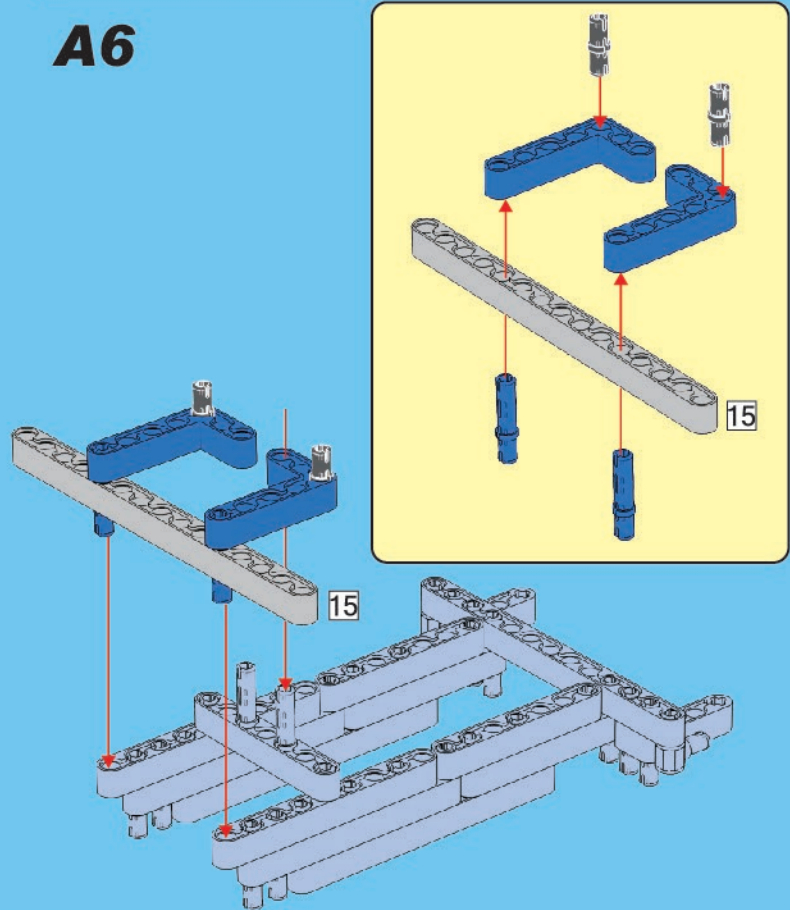

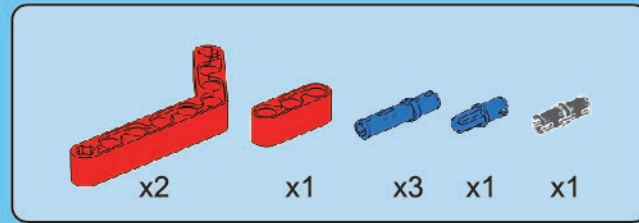
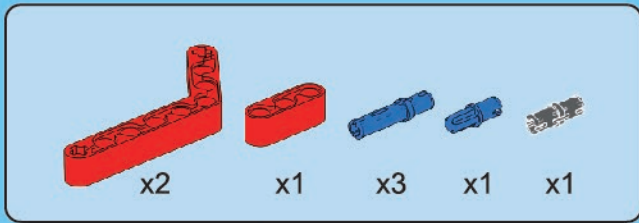

# A7

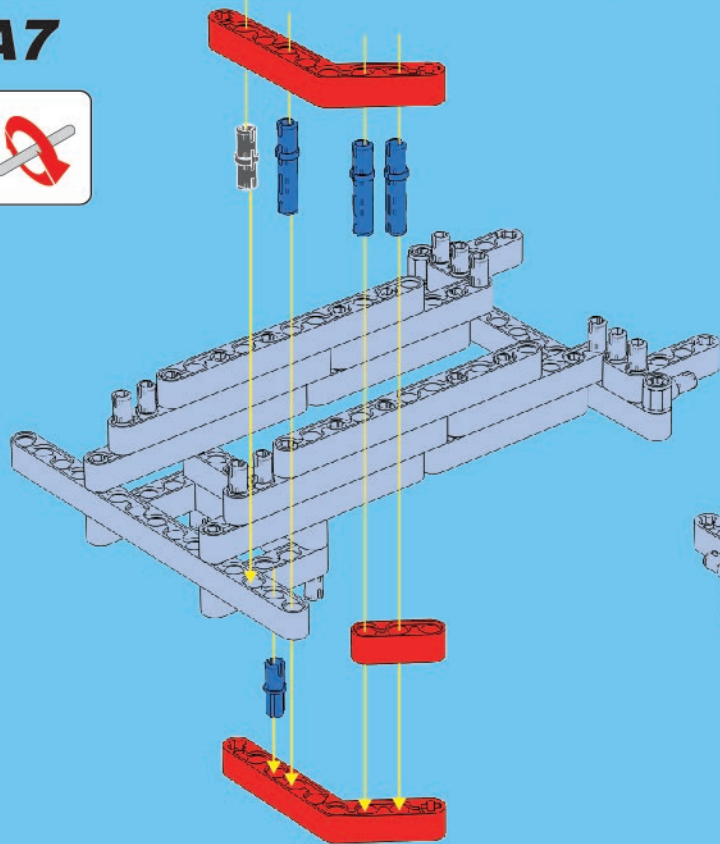

# A8

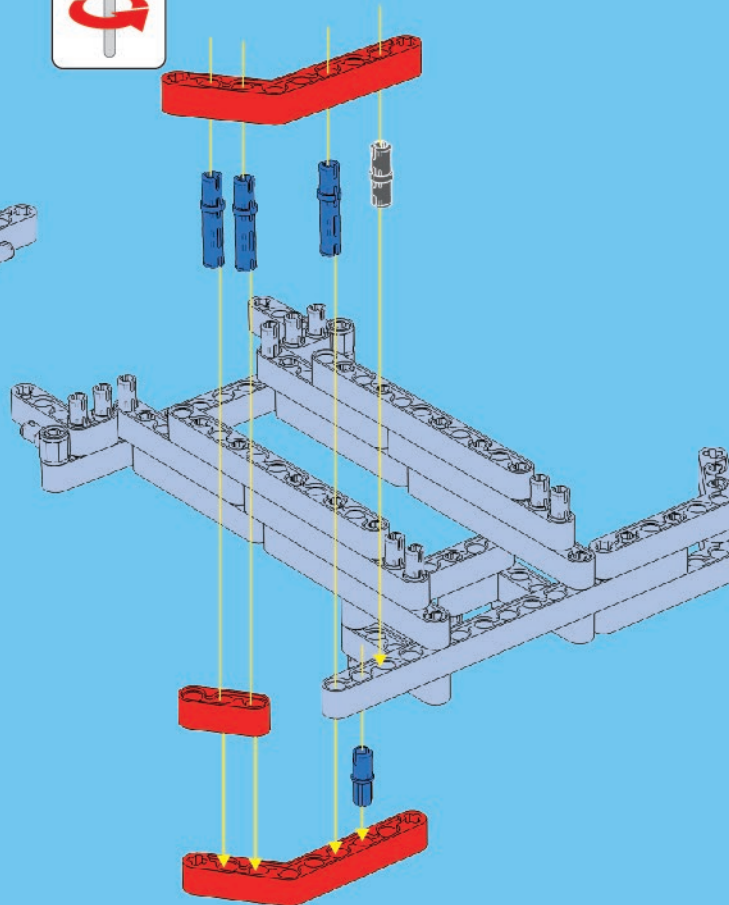

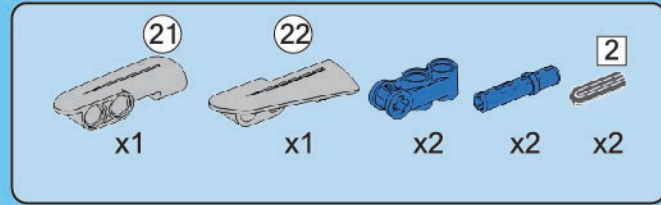
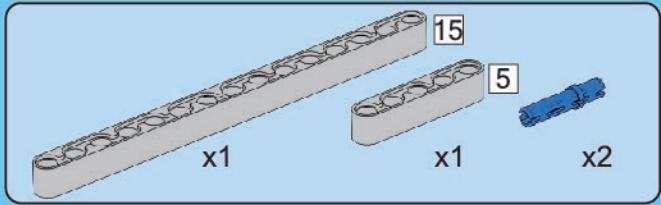

# A9

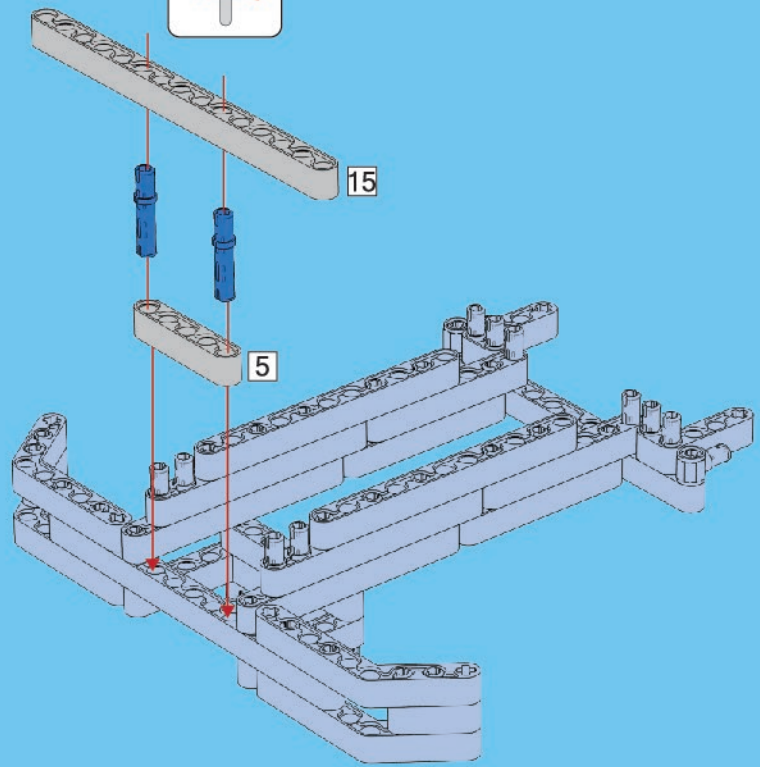

# A10

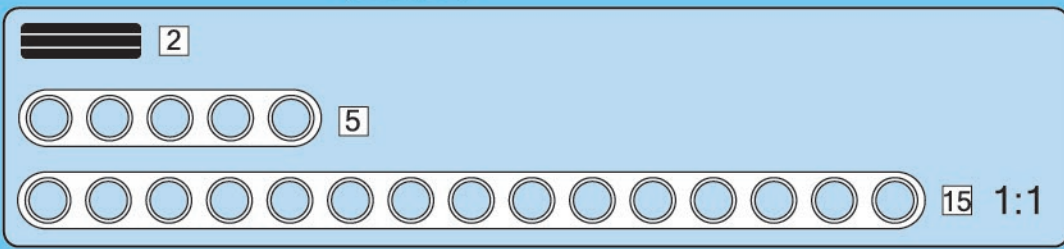
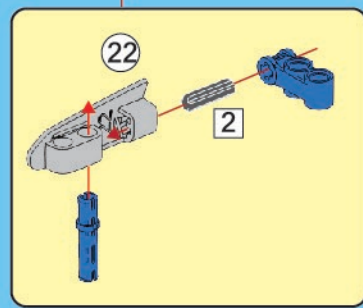
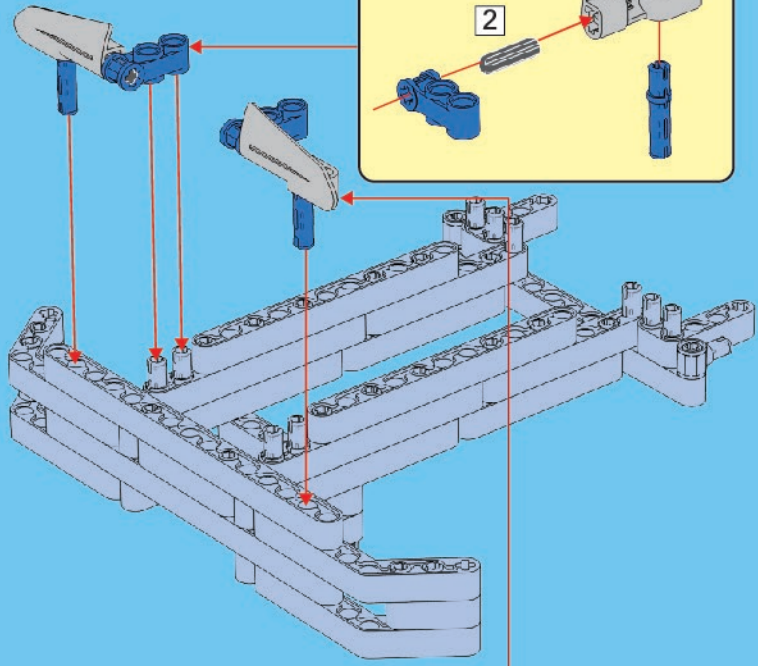
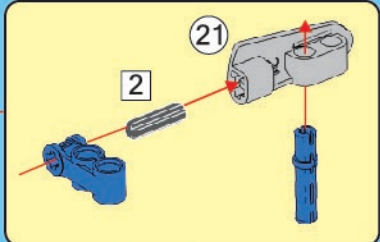

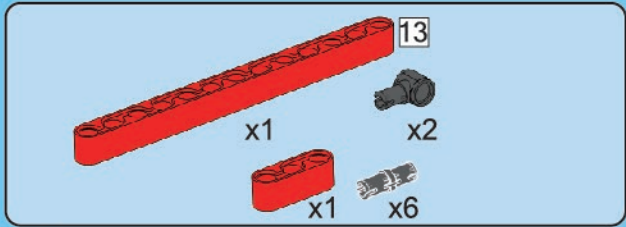
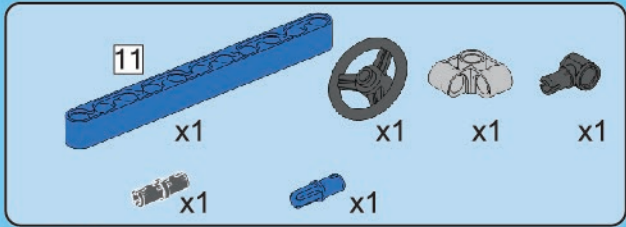

**A11**

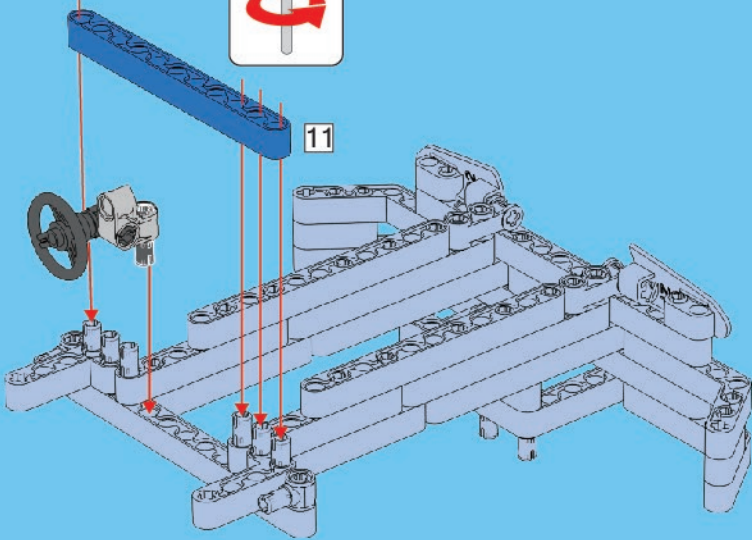

**A12**

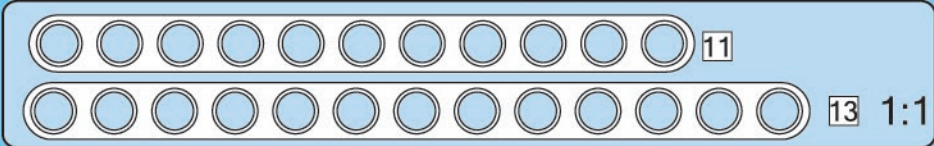
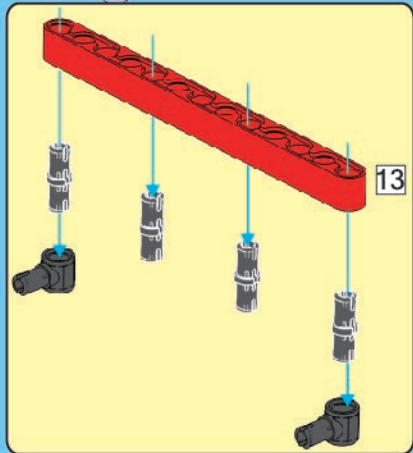
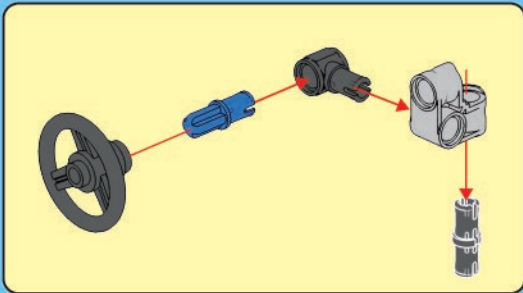
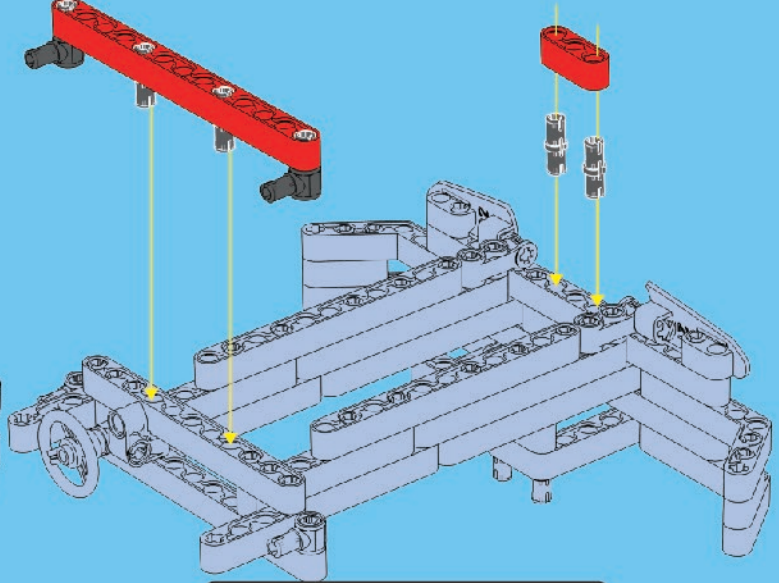



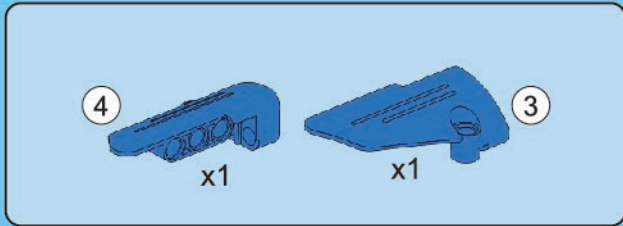

# A13

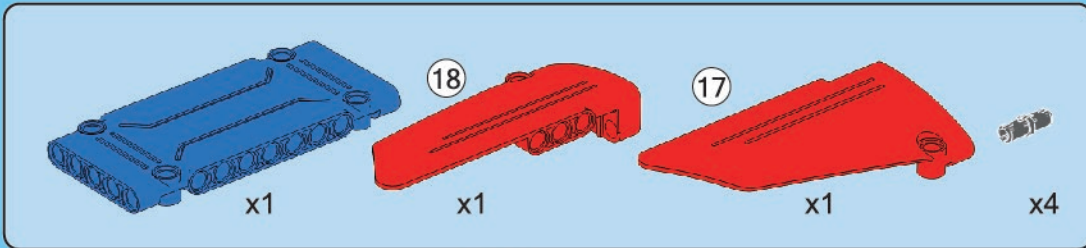
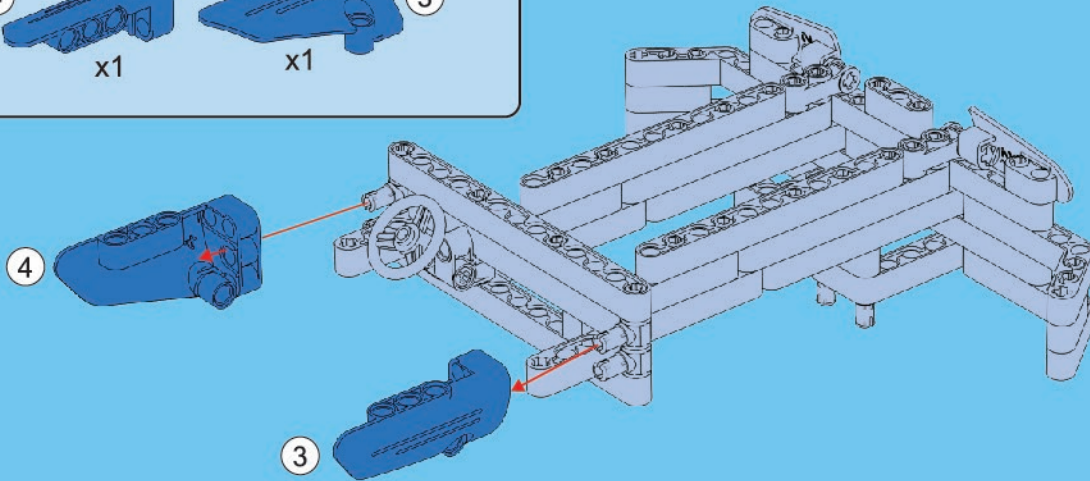

# A14

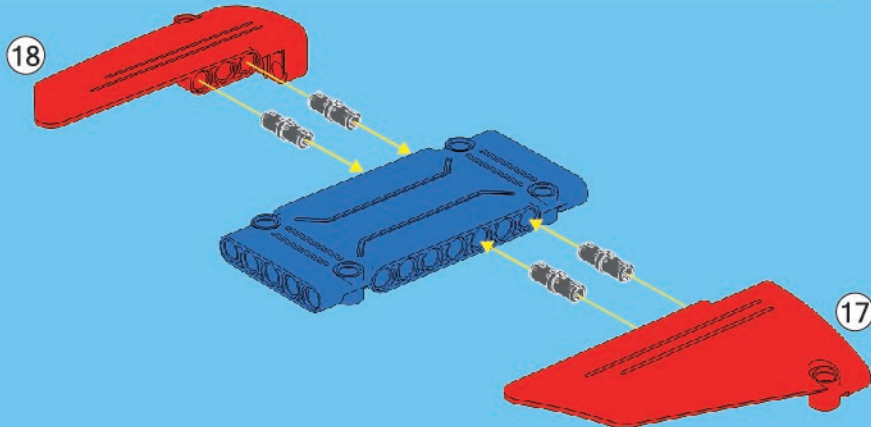

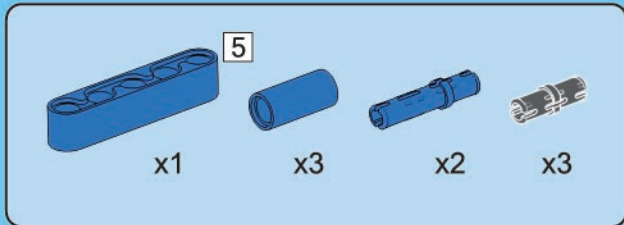

**A15**

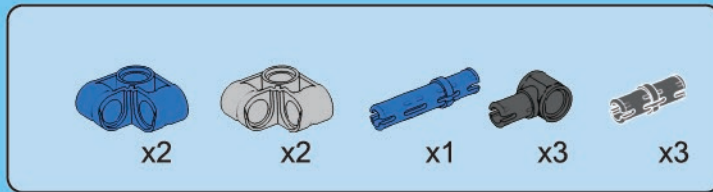

**A16**

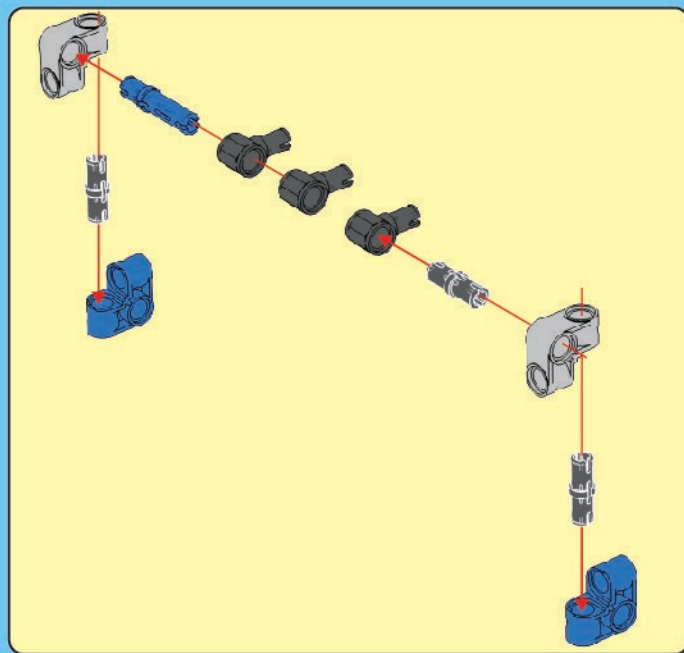
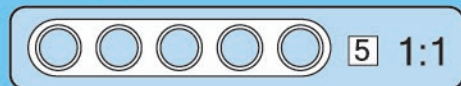
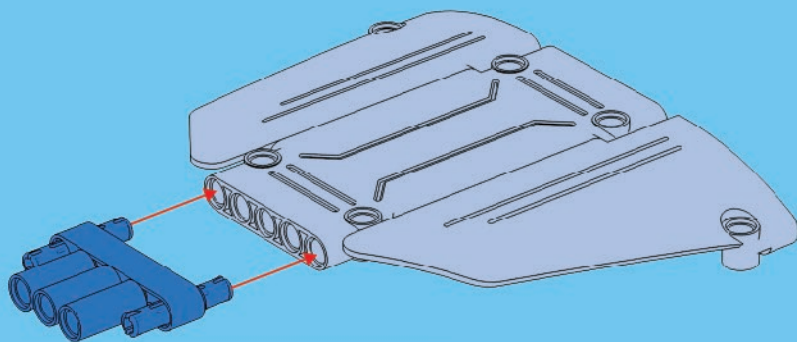
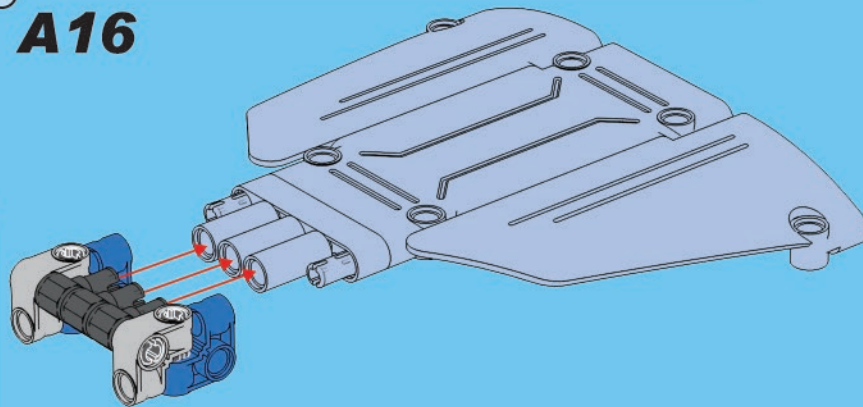
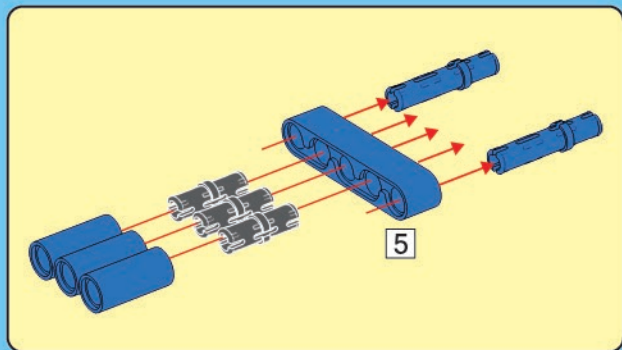

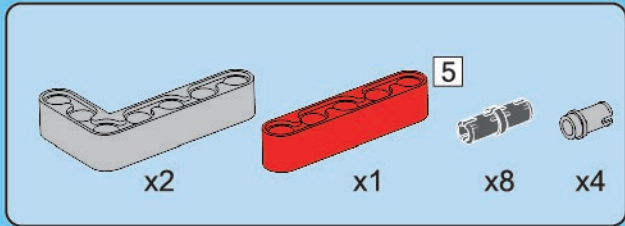

# A17

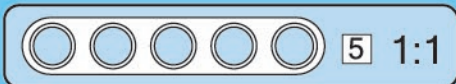
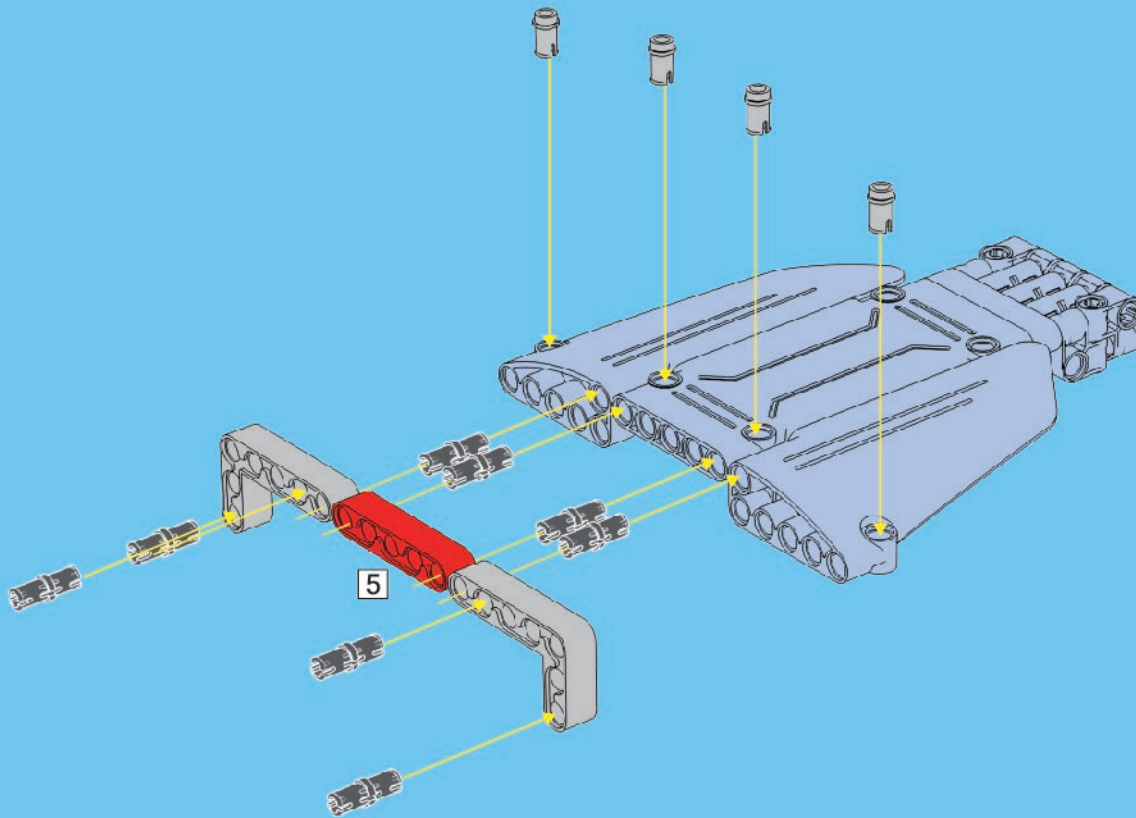

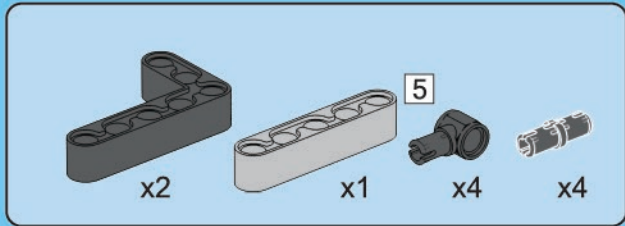

# A18

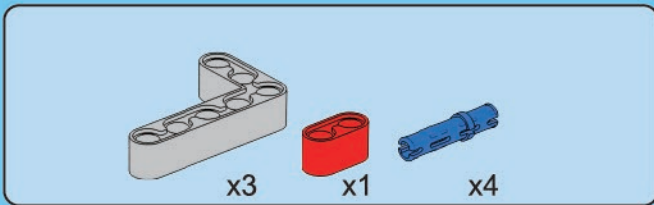
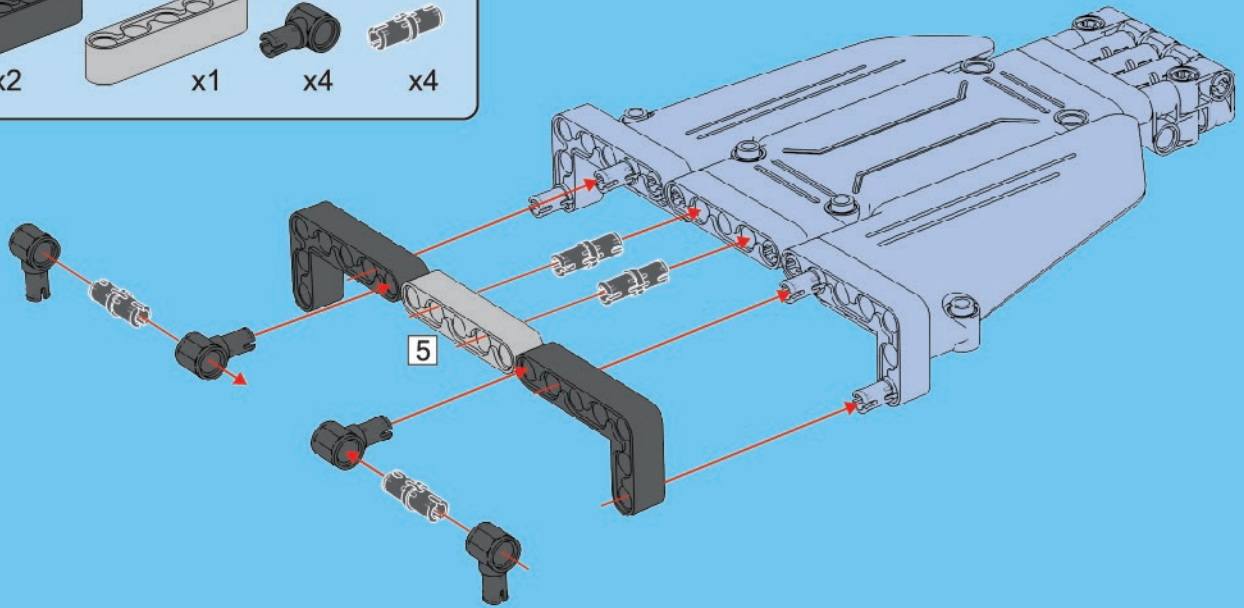

# A19

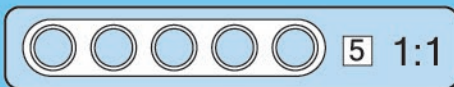
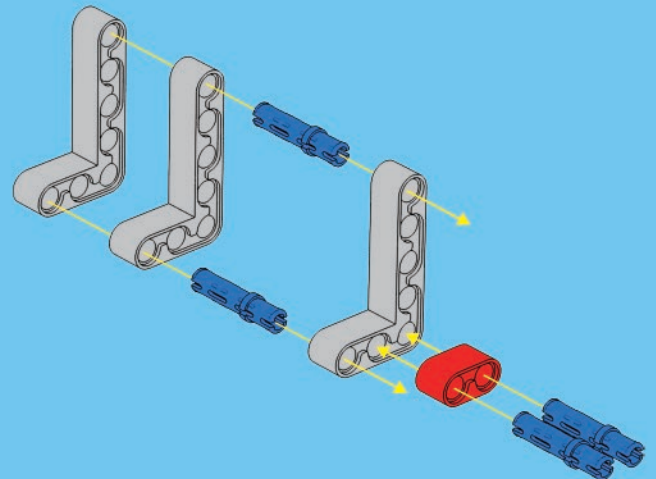

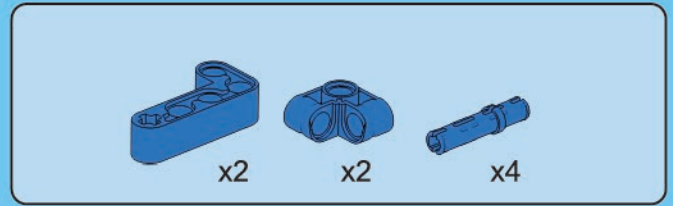
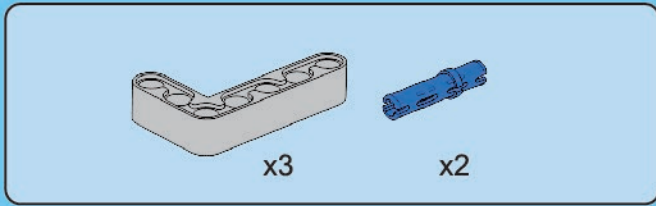

## A20

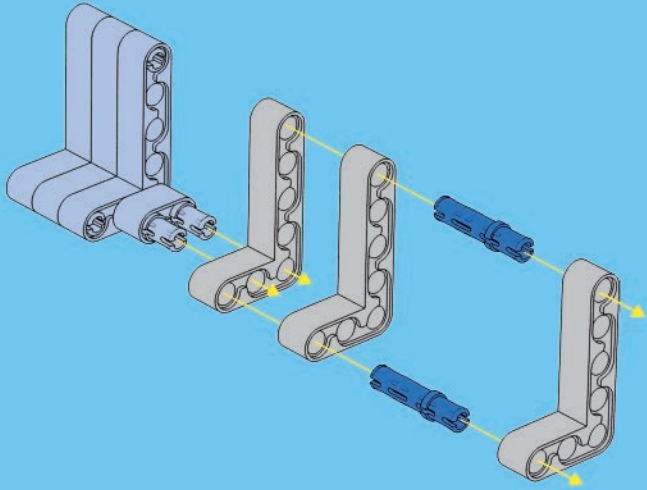

## A21

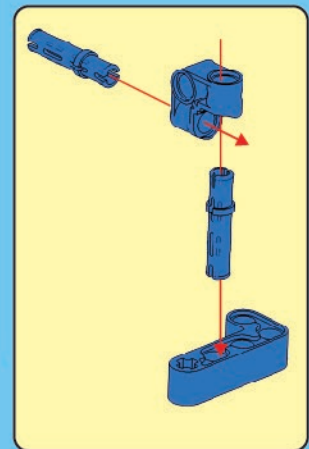
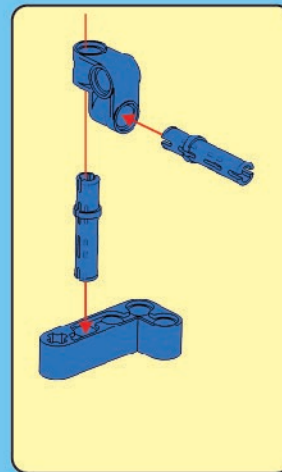
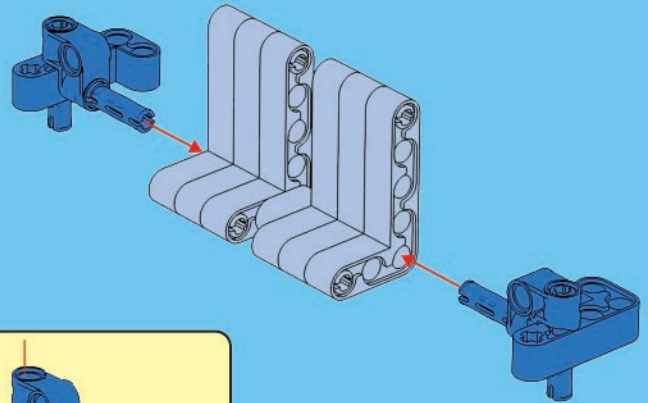

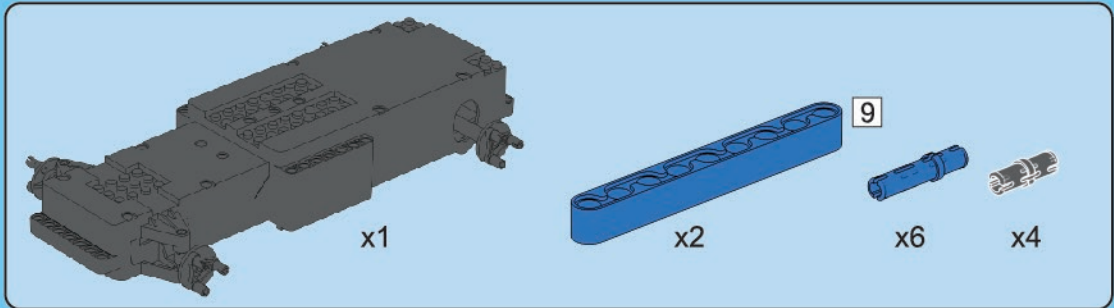

# A22

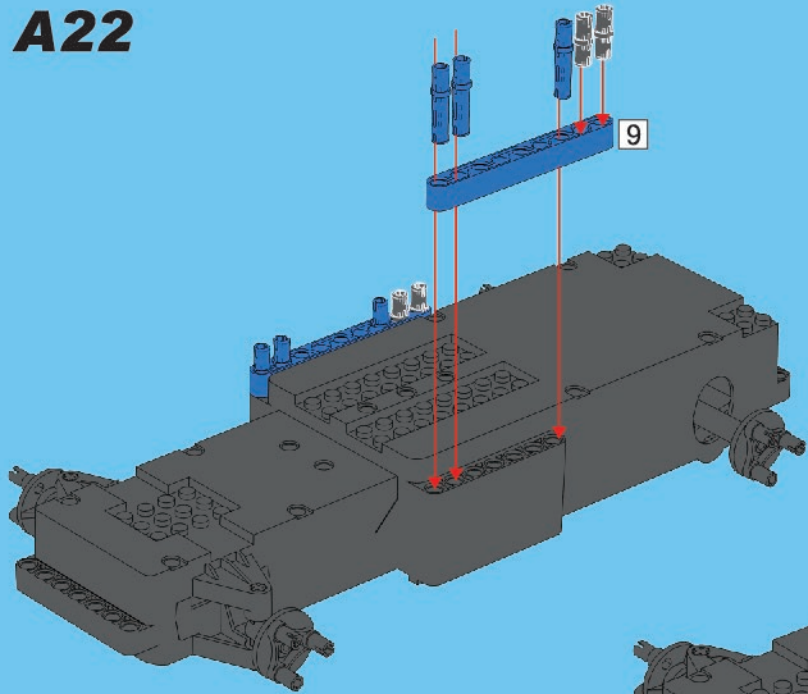

# A23

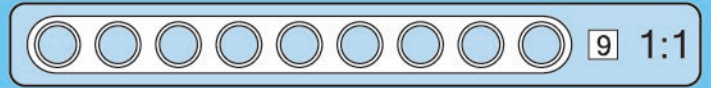
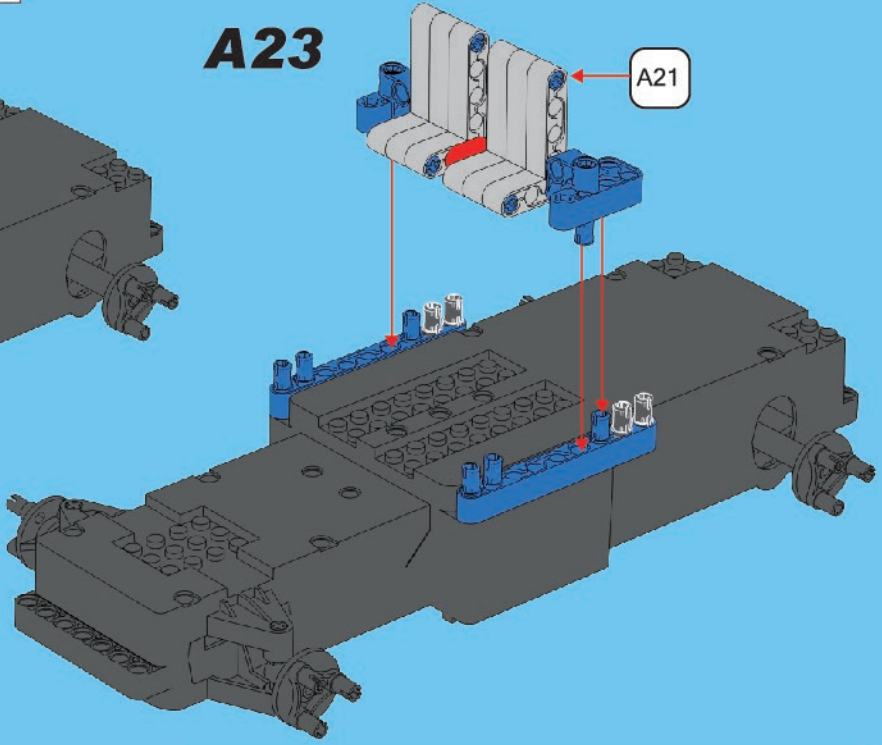

# A24

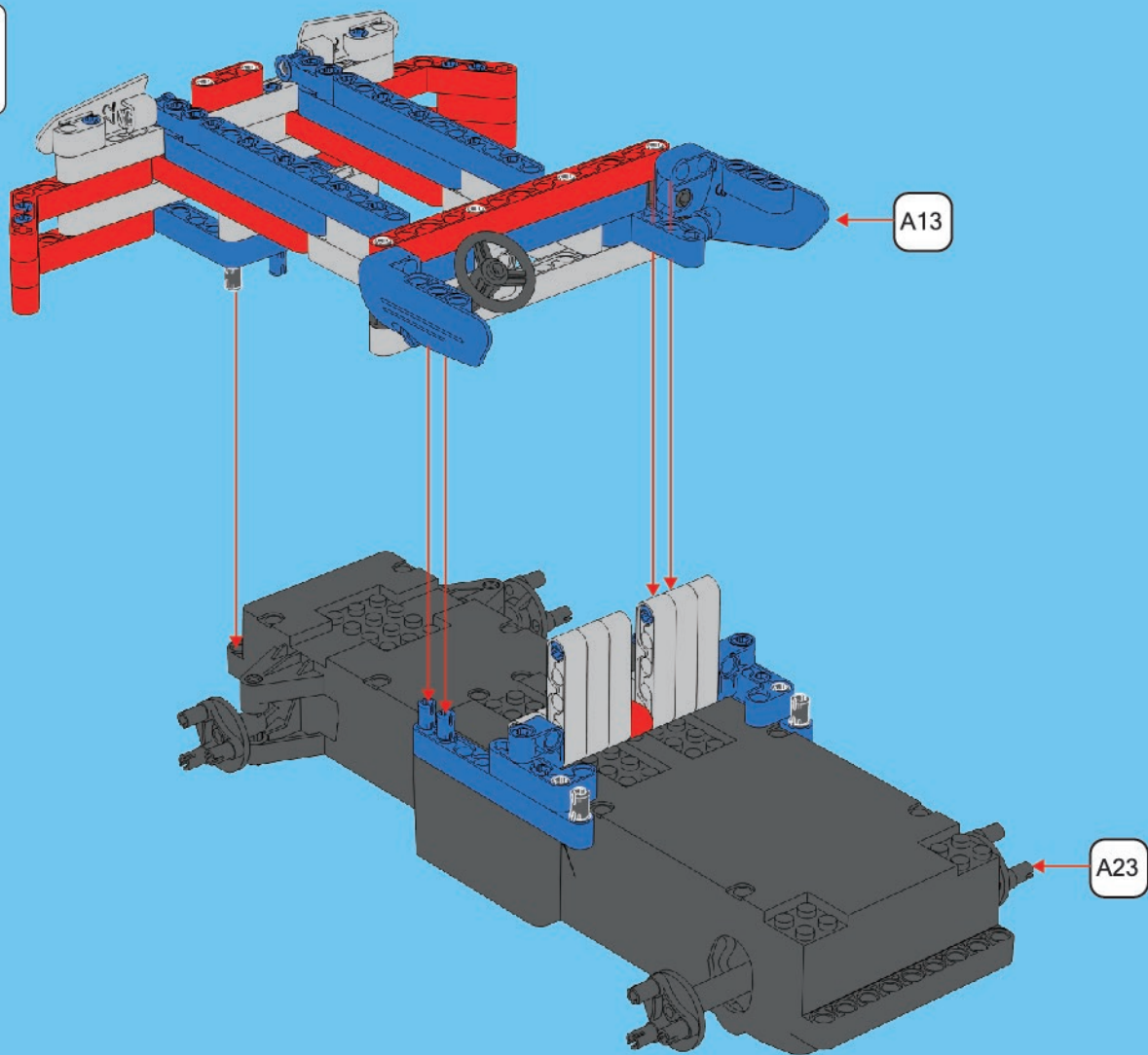

# A25

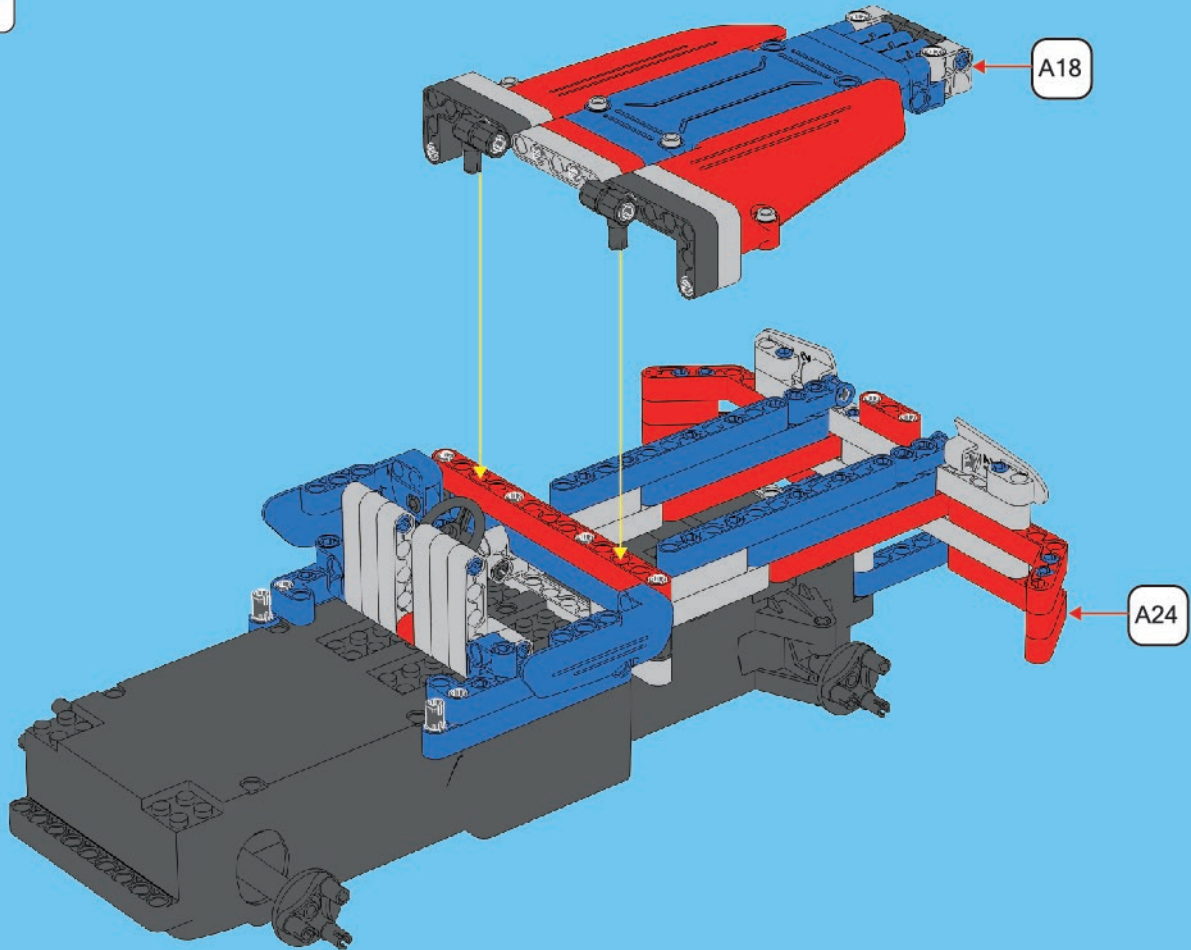



**B**

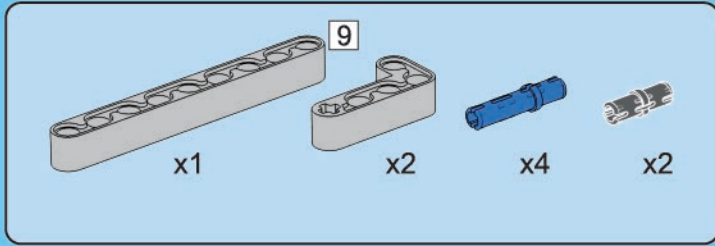
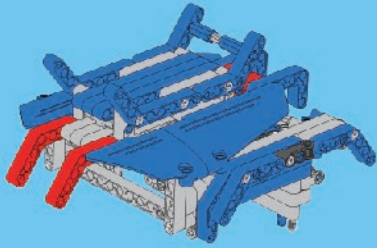

**B1**

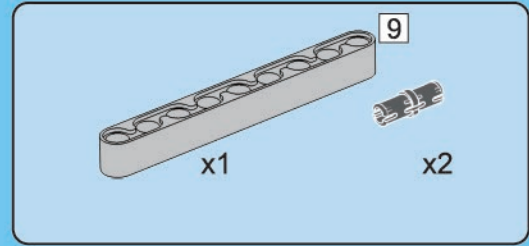
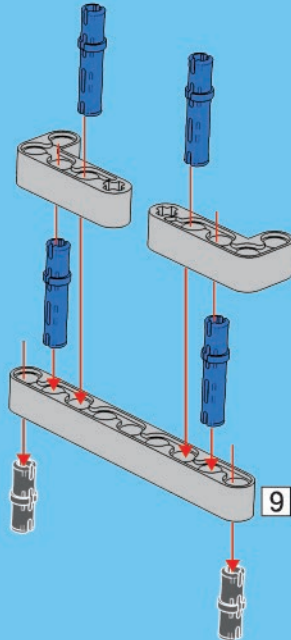

**B2**

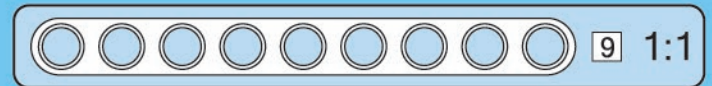
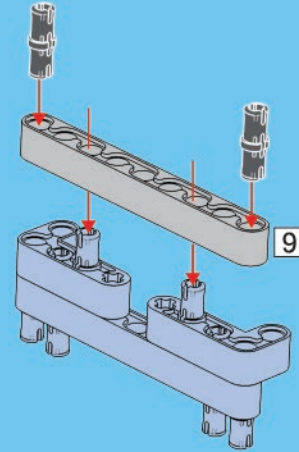

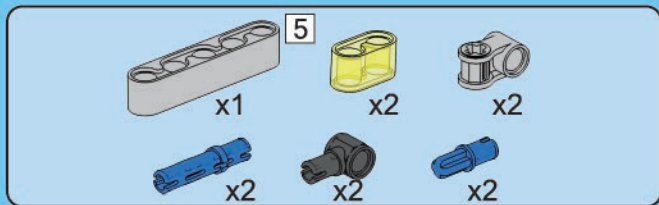

**B3**

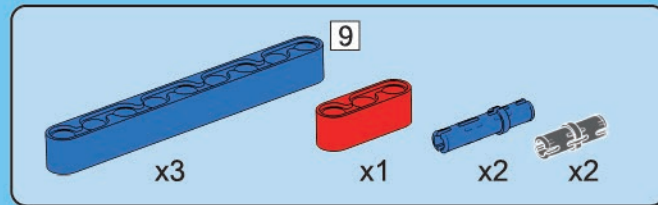
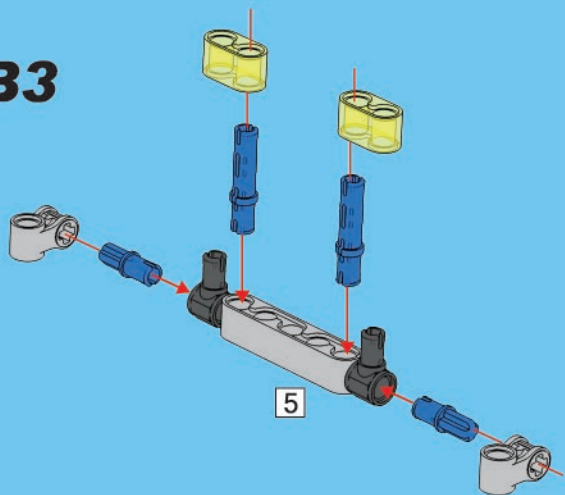

**B4**

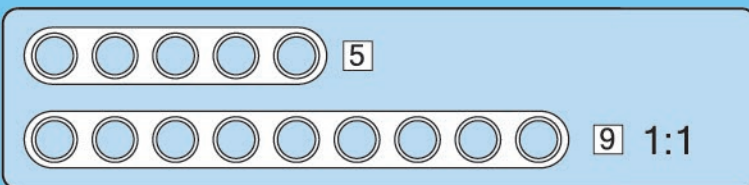
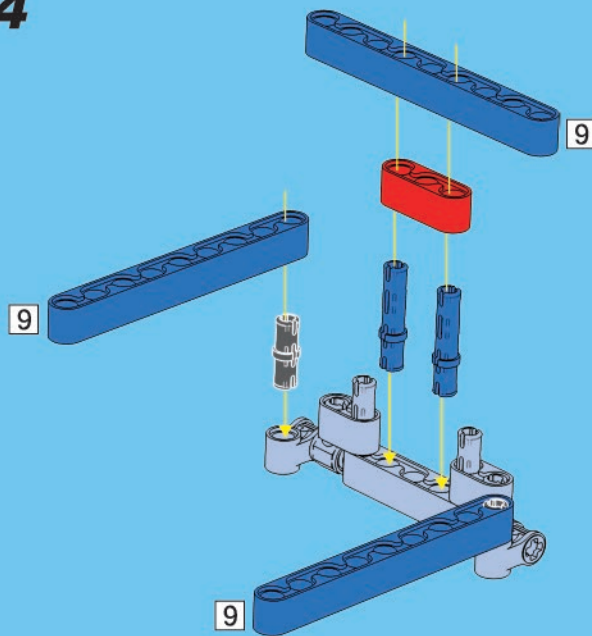

# B5

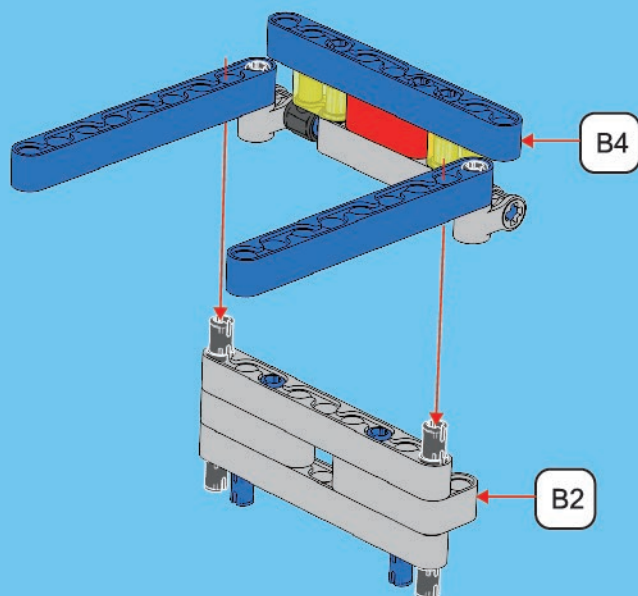
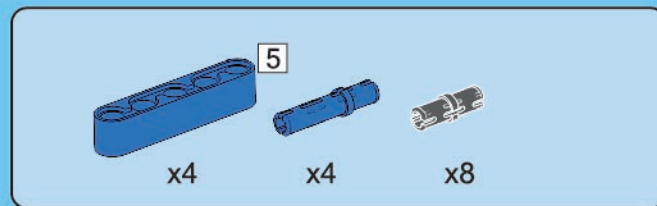

# B6

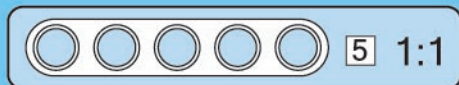
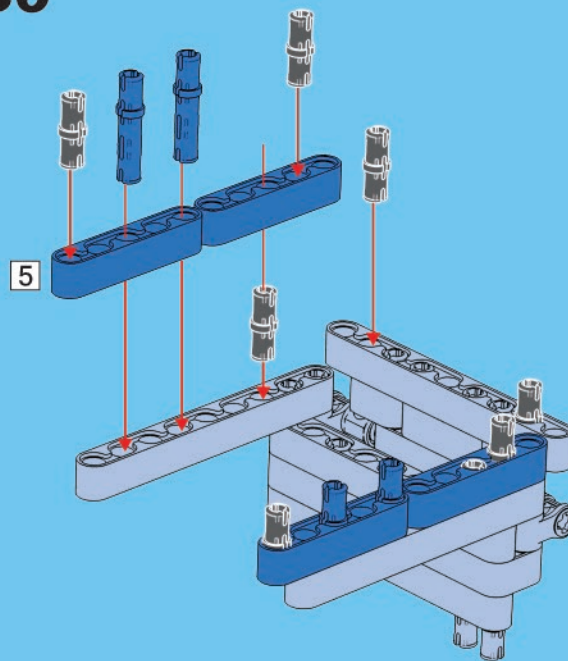

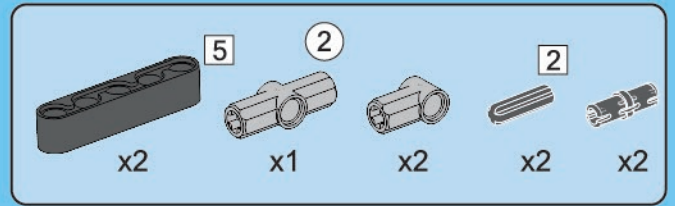
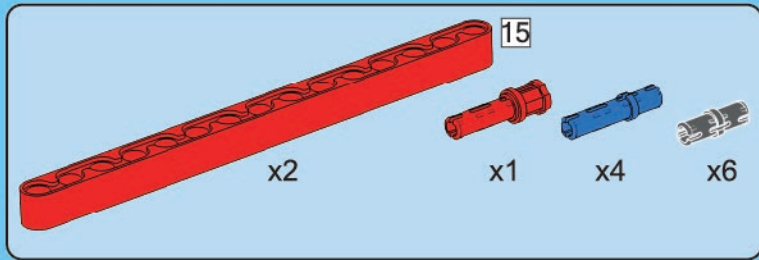

## B7

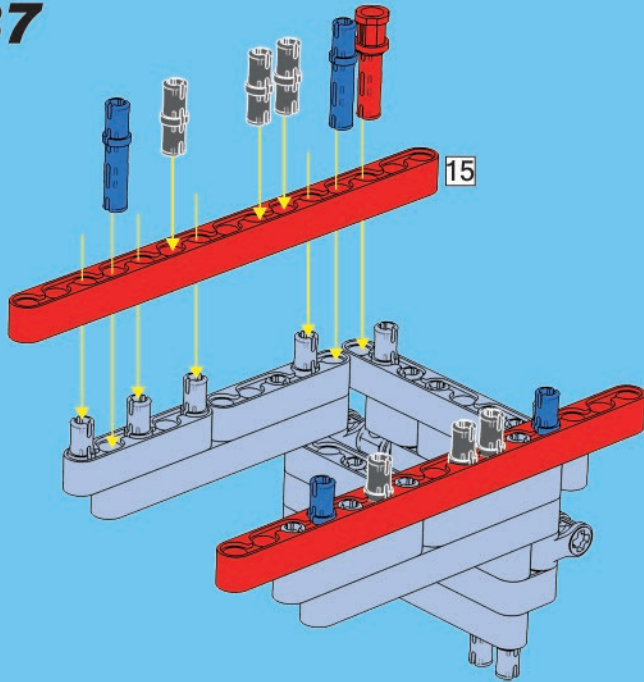

## B8

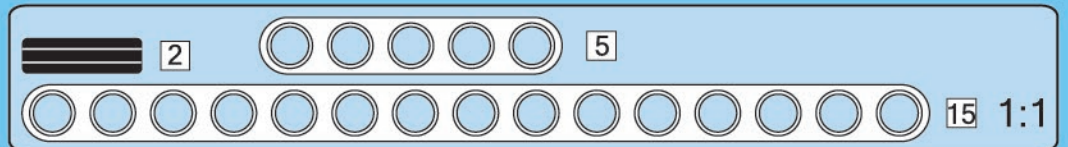
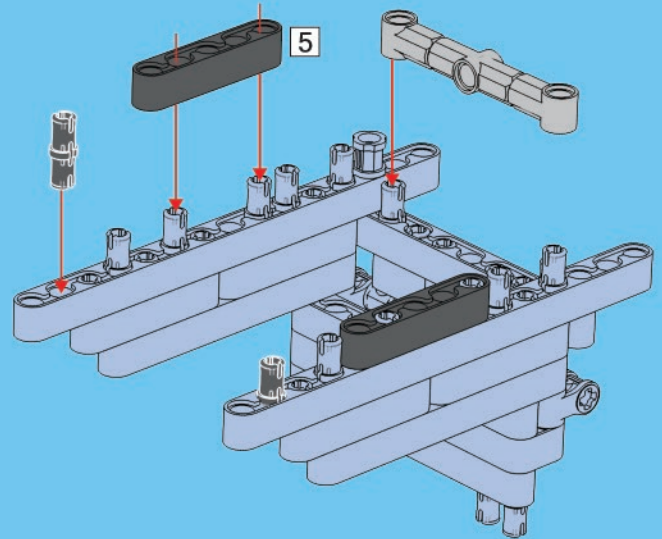
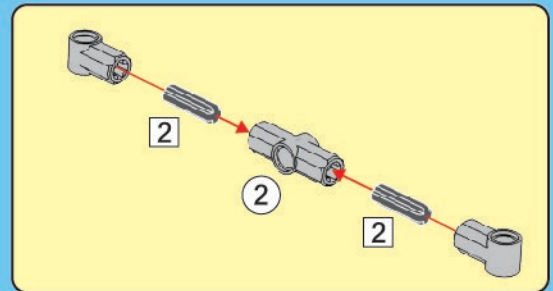

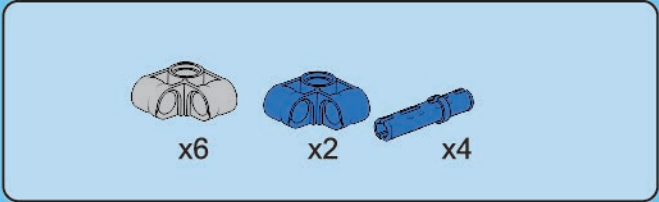

# B9

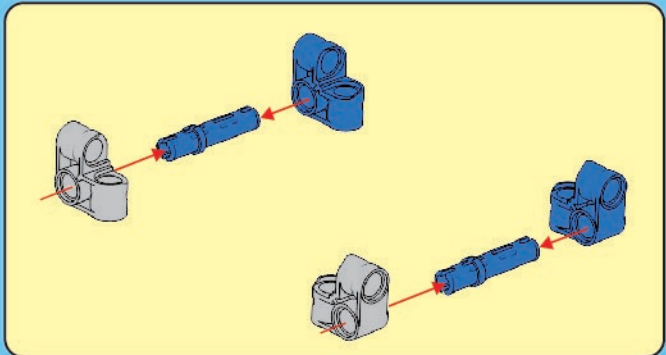
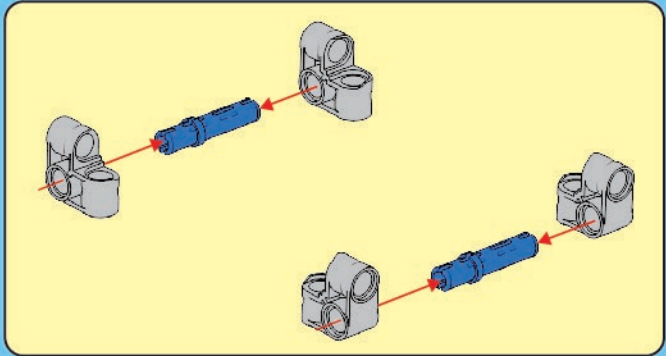
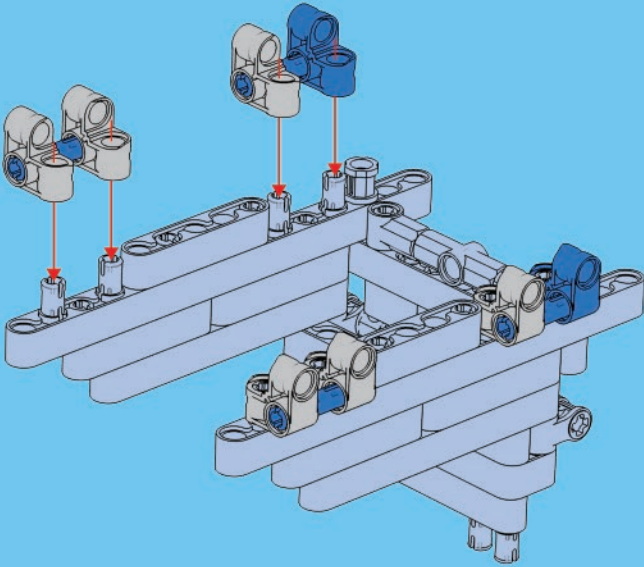

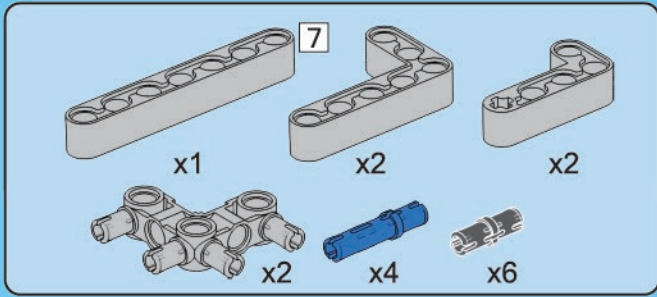

**B10**

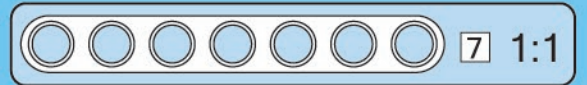
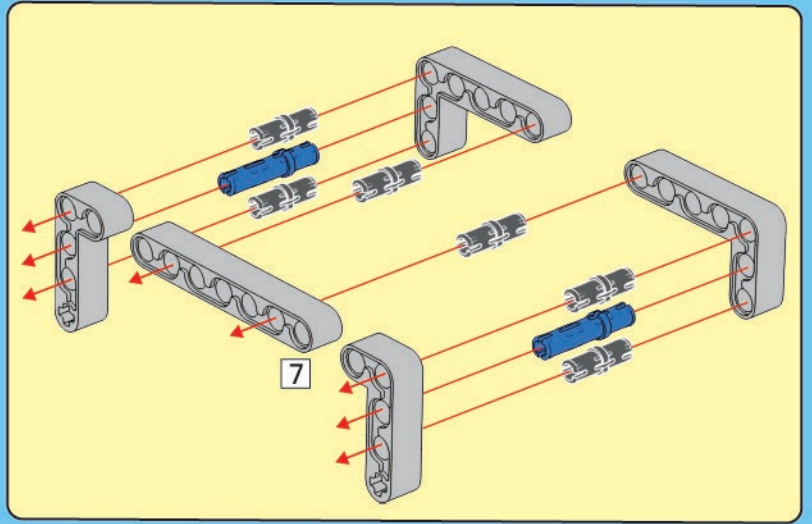
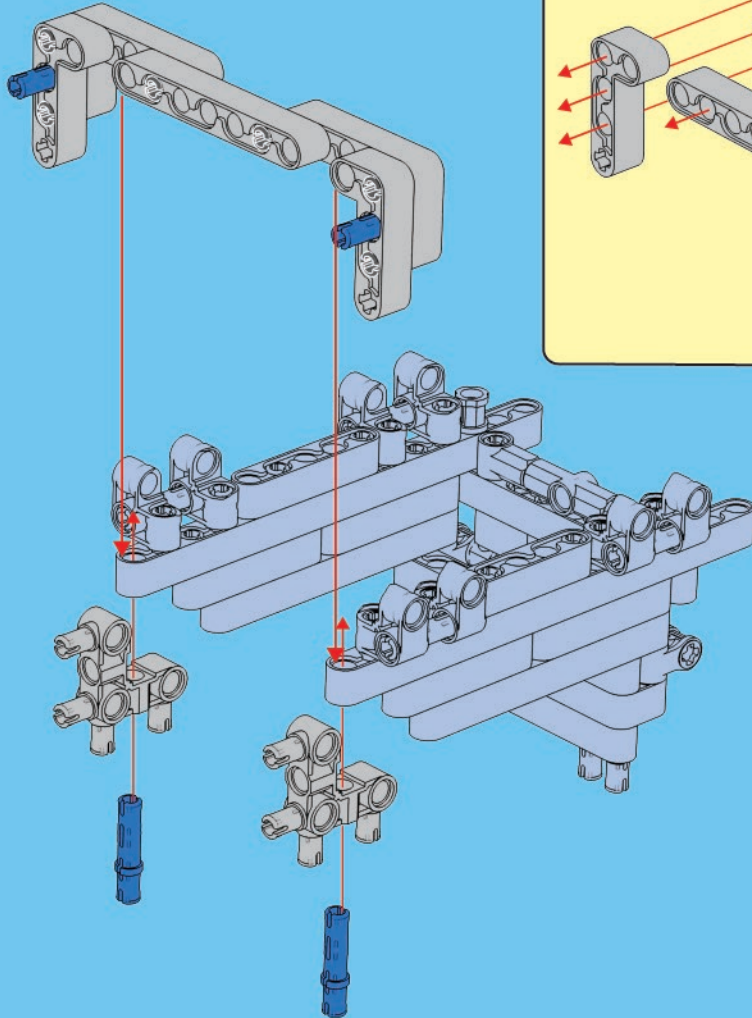

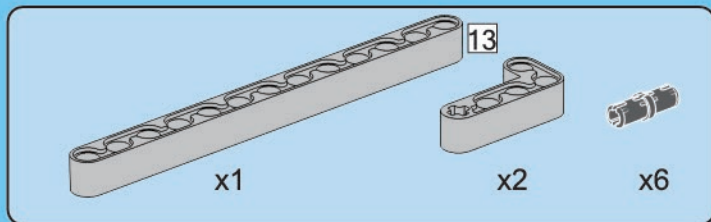

**B11**

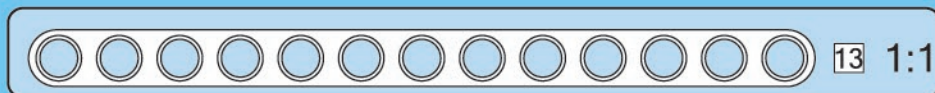
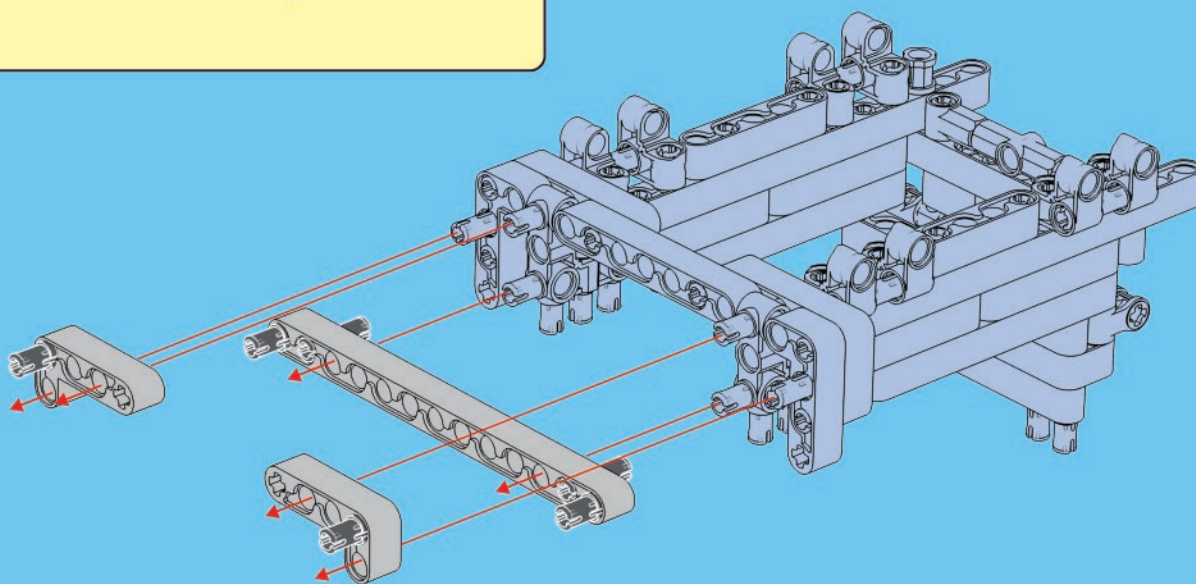
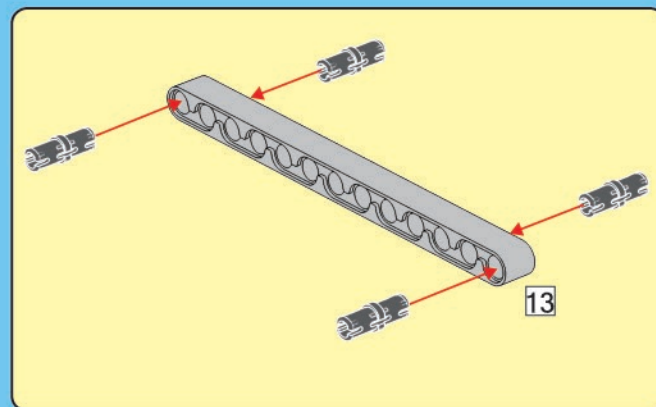
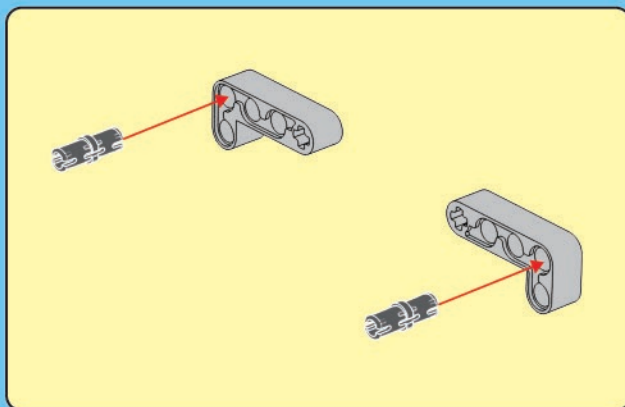

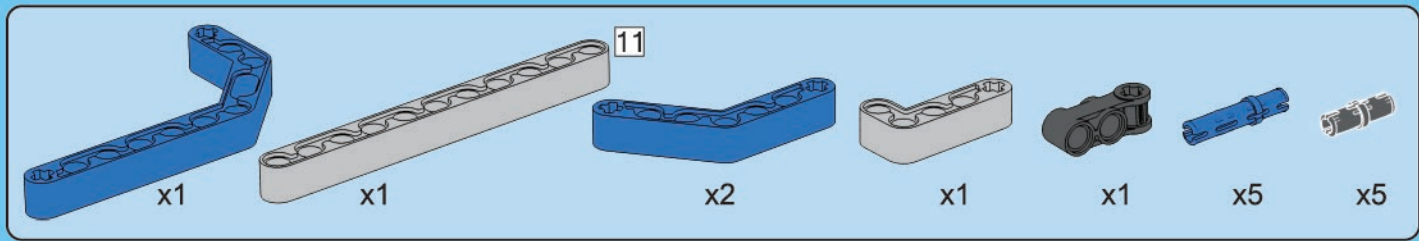

# B12

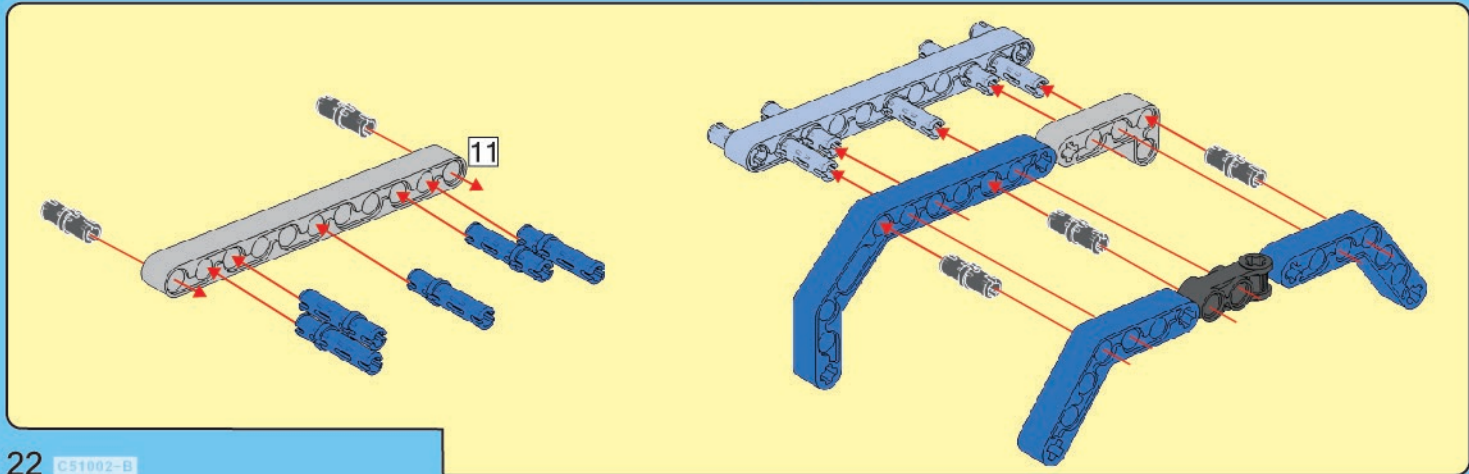
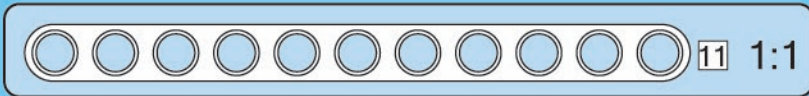
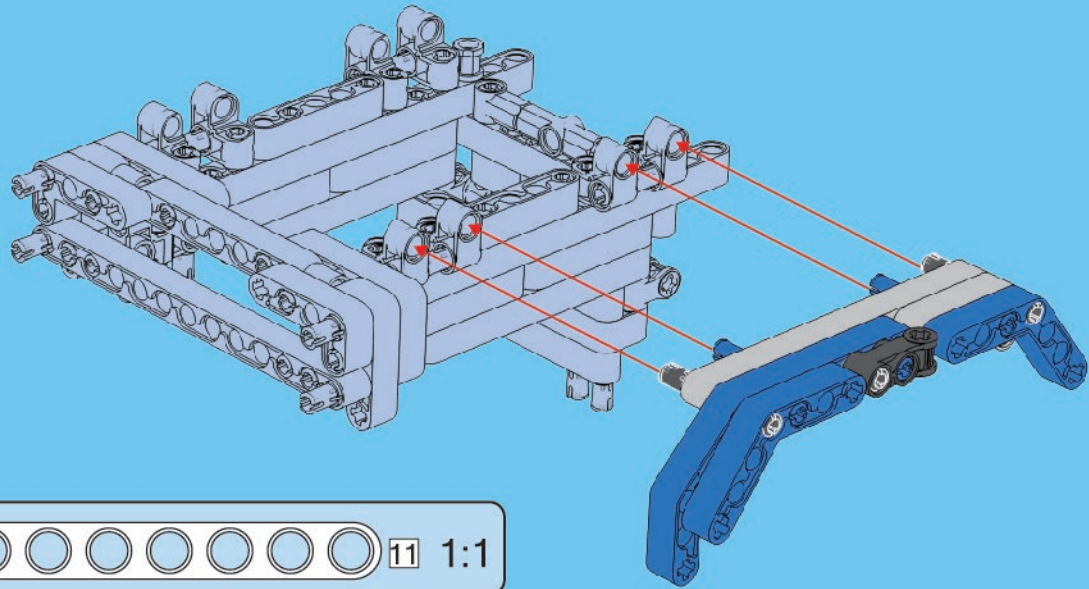



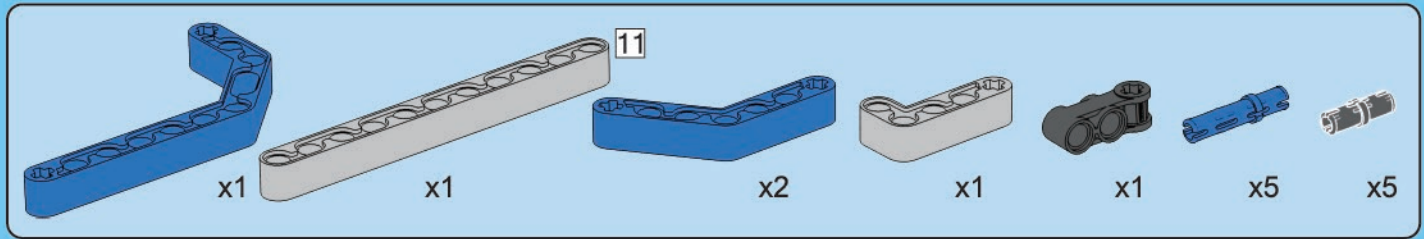

# B13

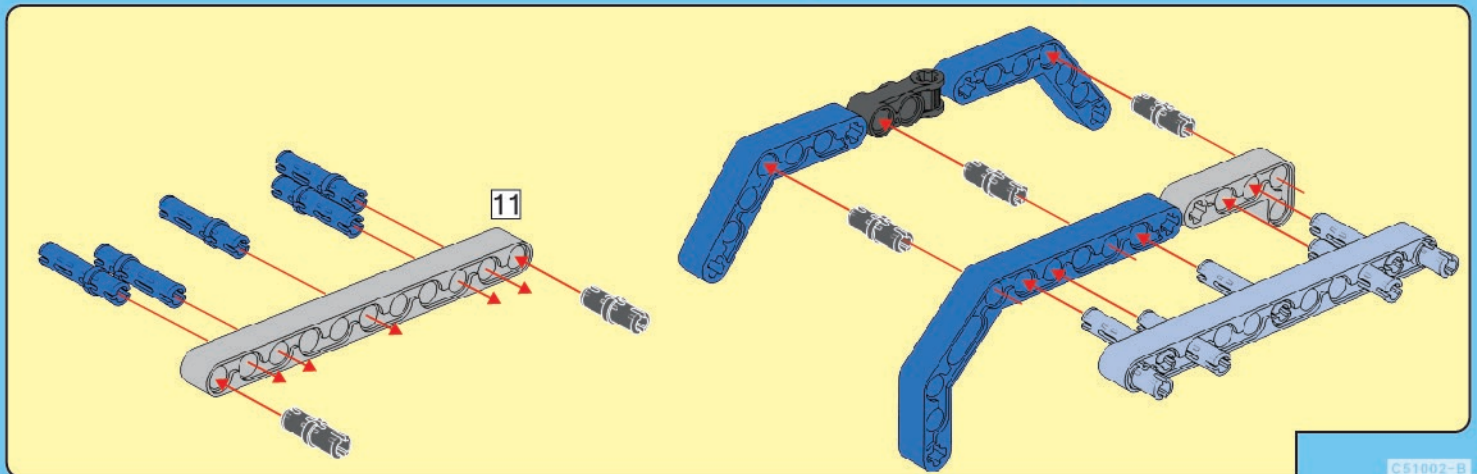
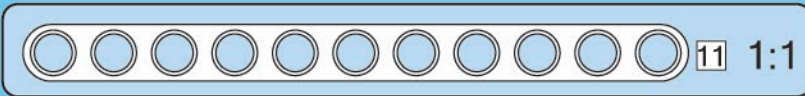
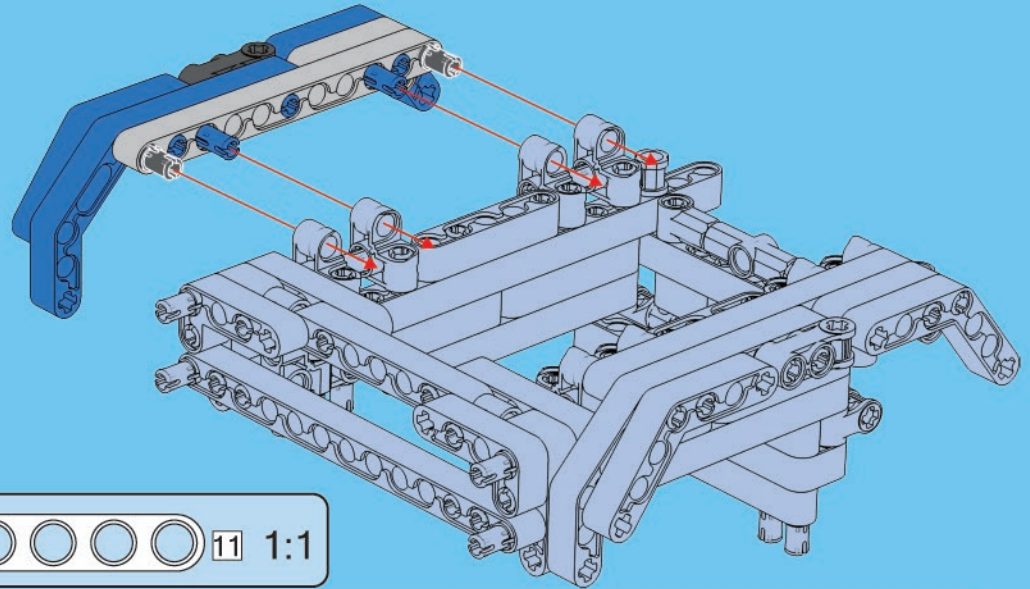

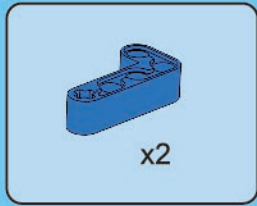

# B14

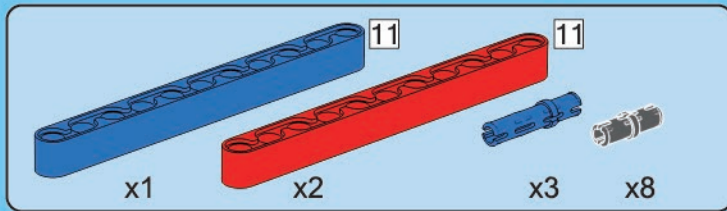
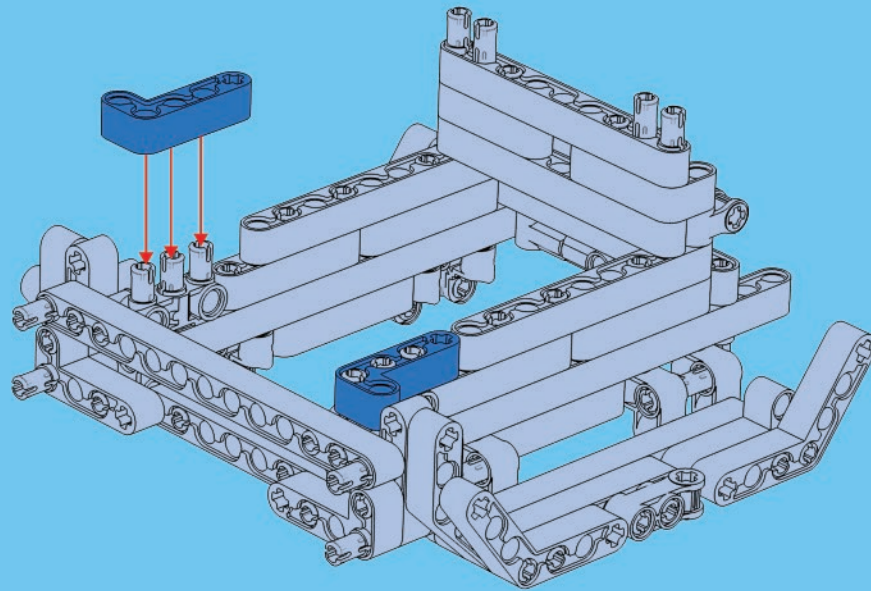

# B15

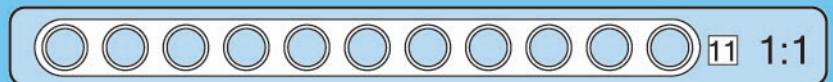
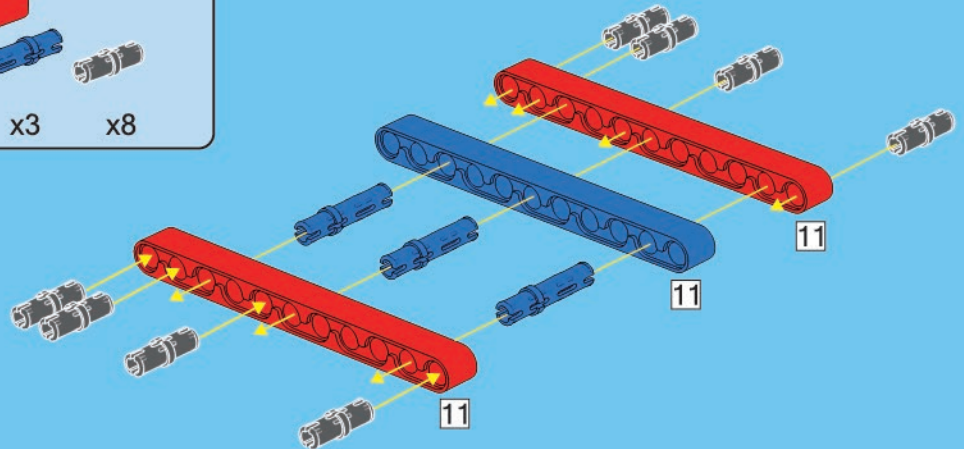

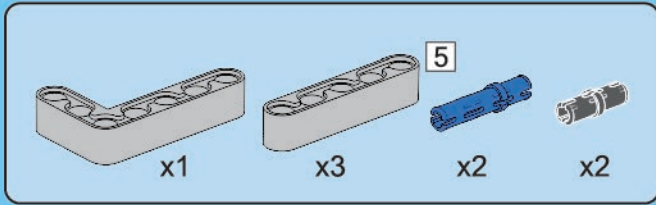

# B16

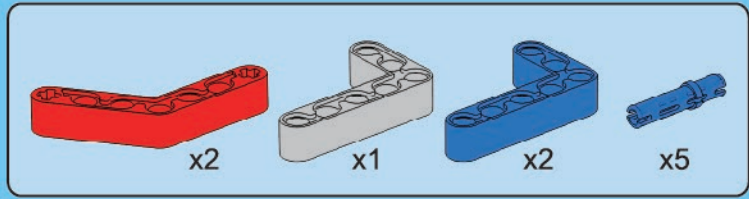
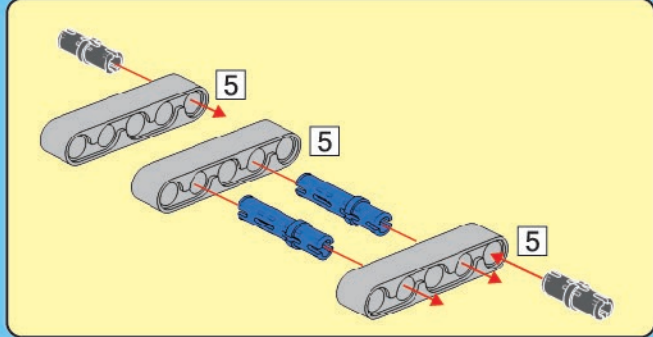
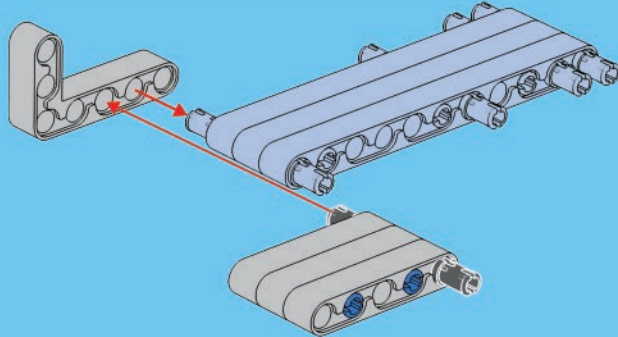

# B17

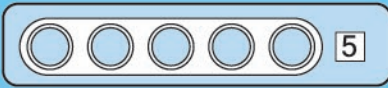
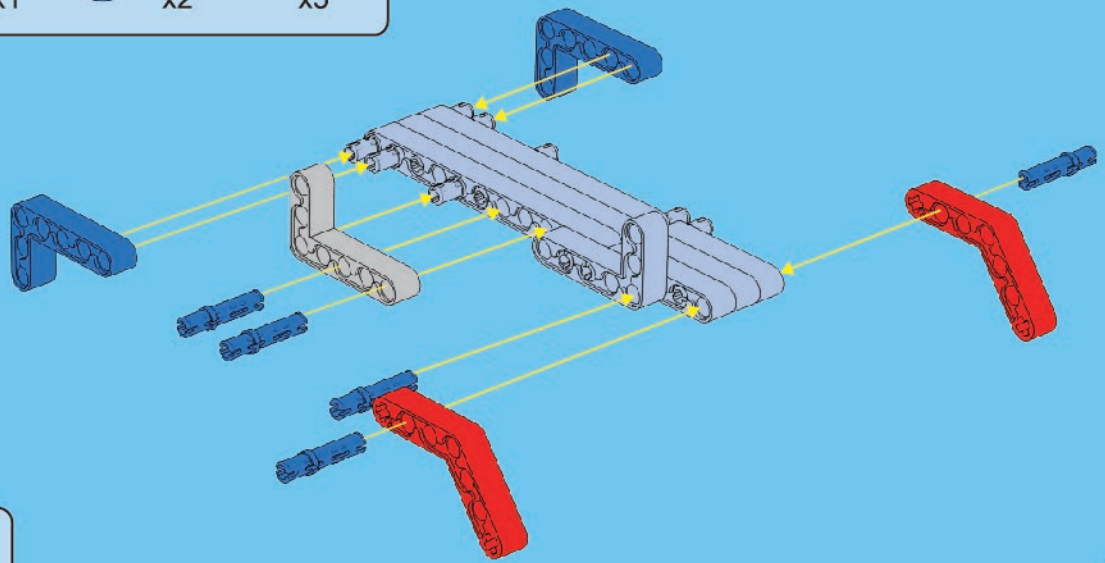

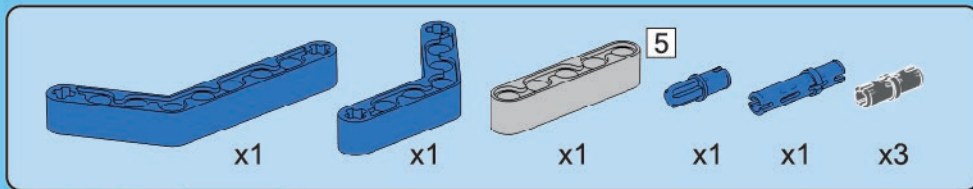

**B18**

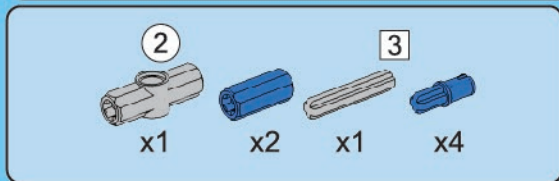
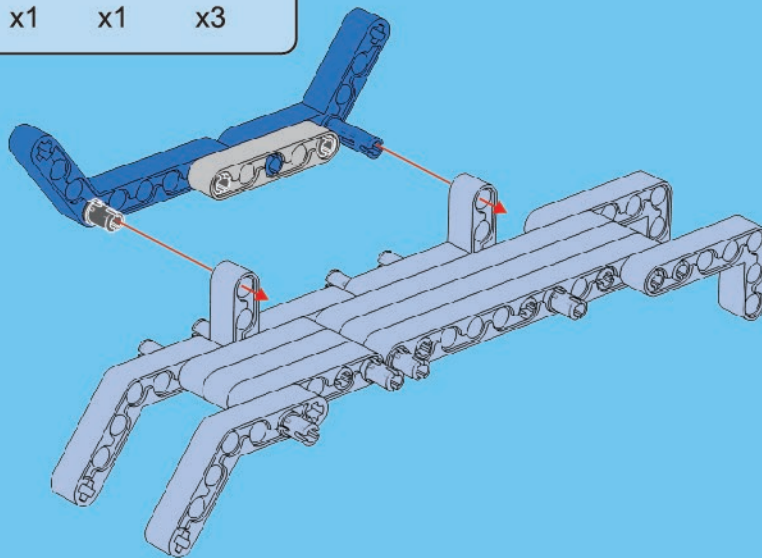
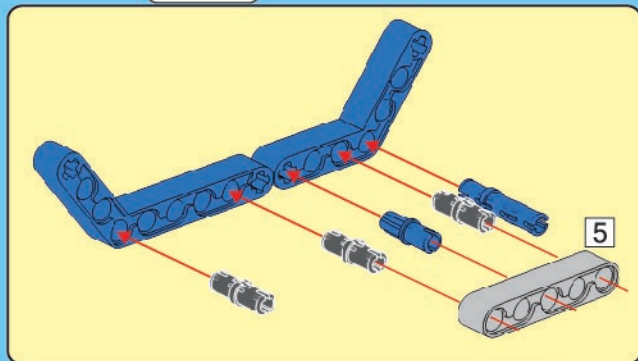

**B19**

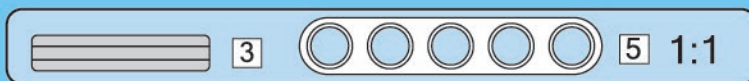
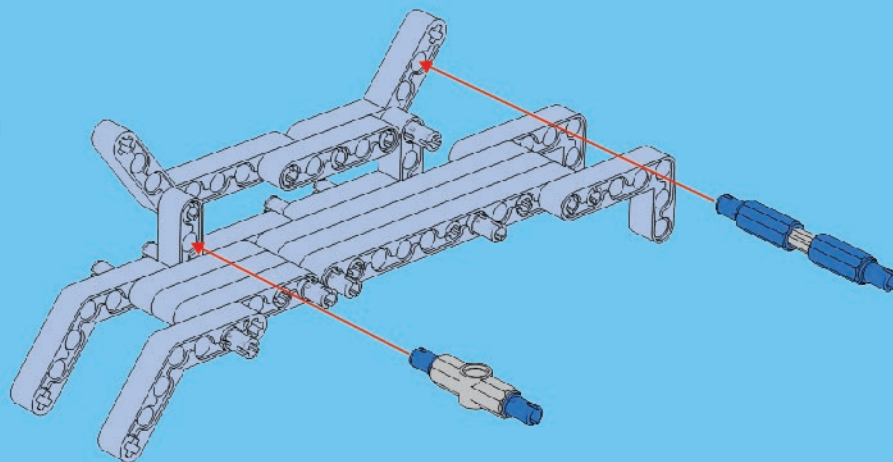
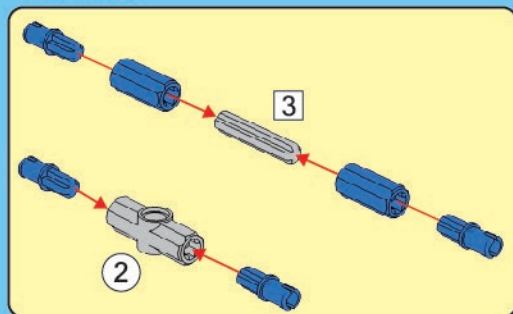

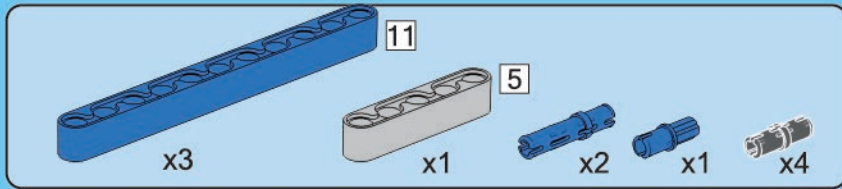

## B20

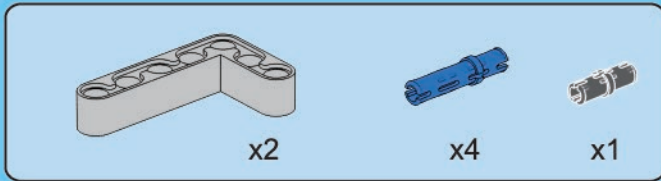
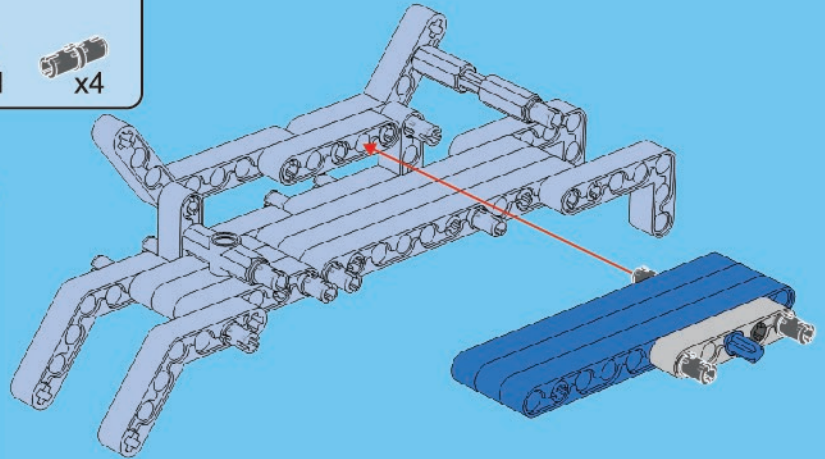
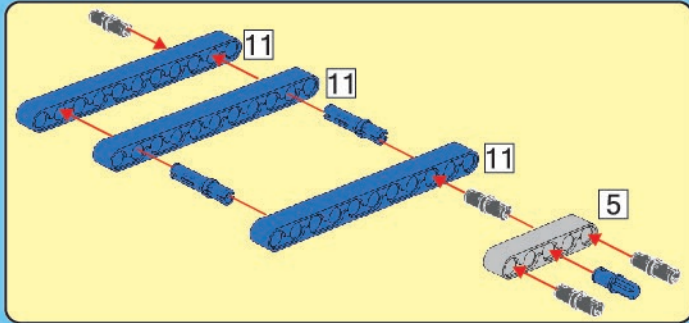

## B21

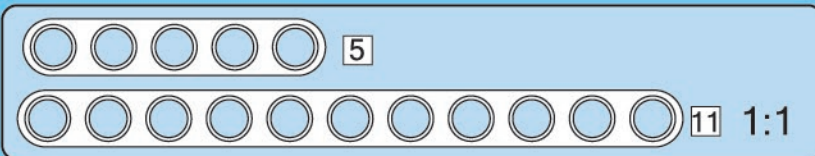
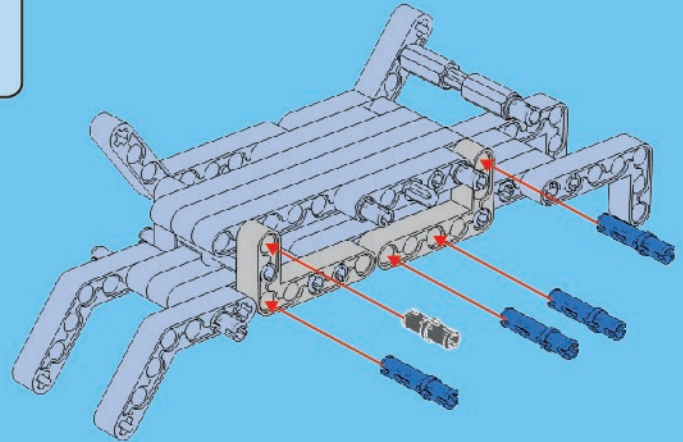

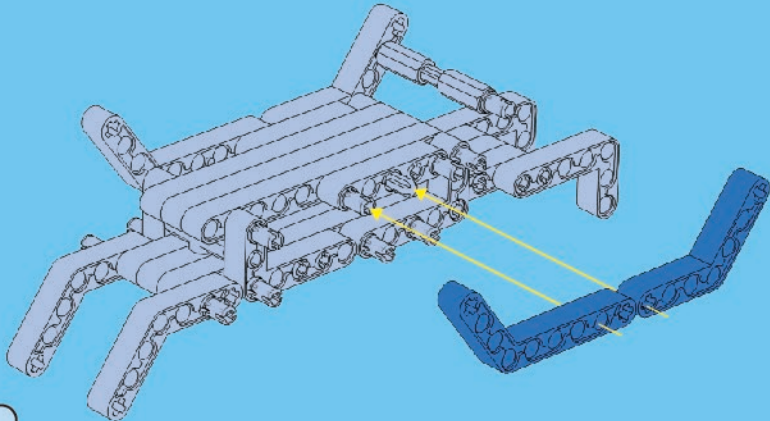
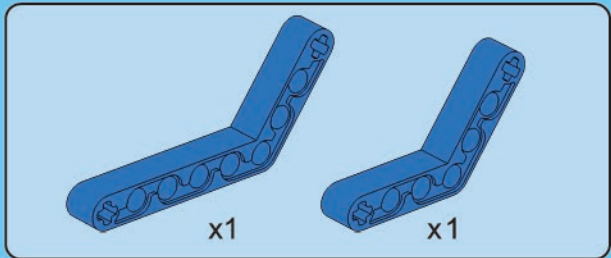

## B22

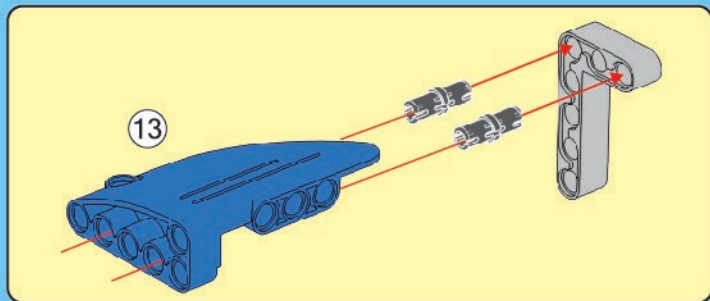
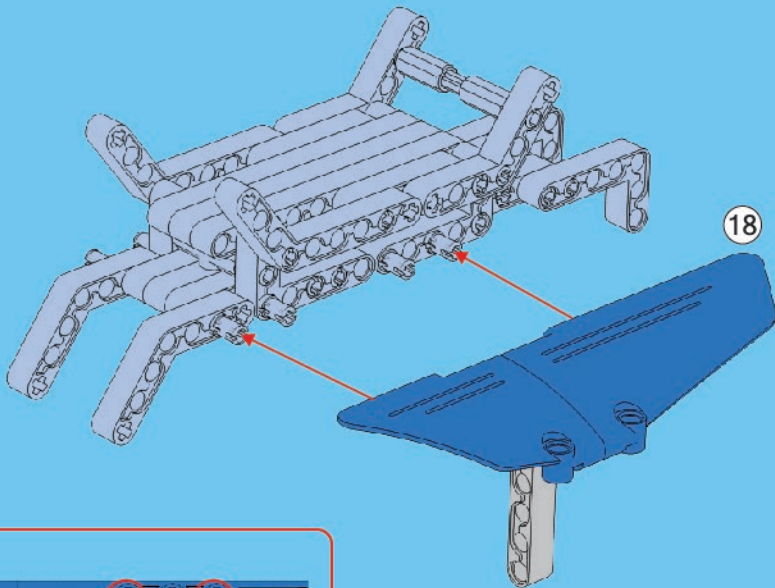
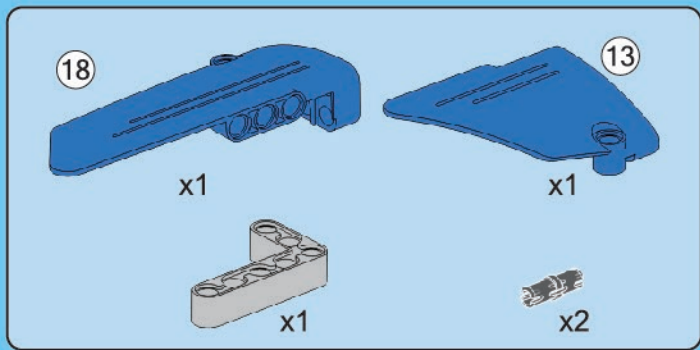

## B23

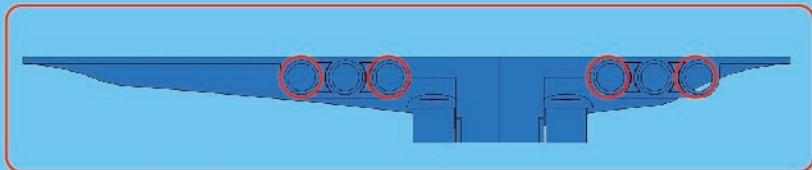

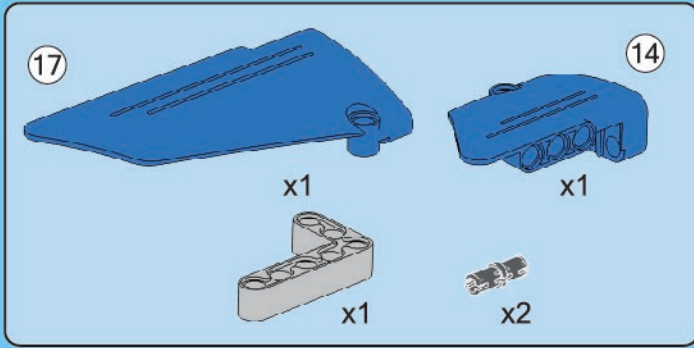

**B24**

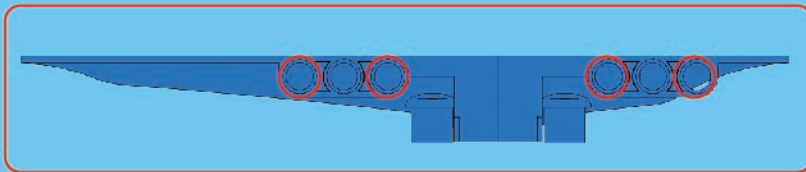
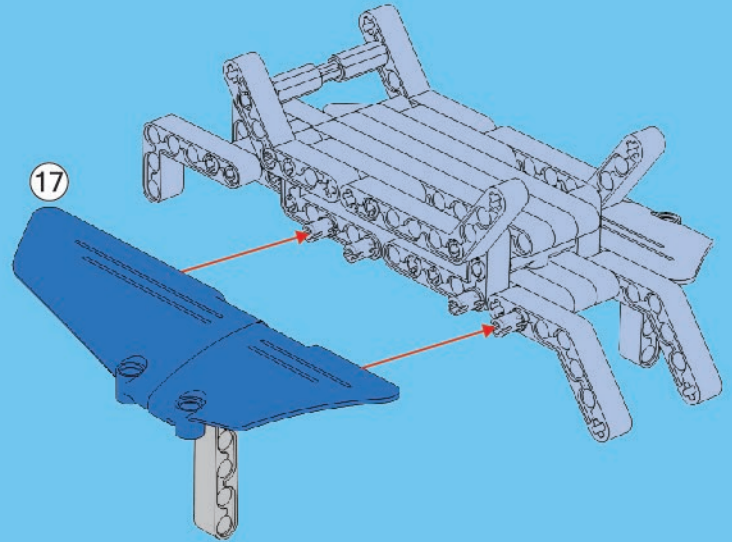
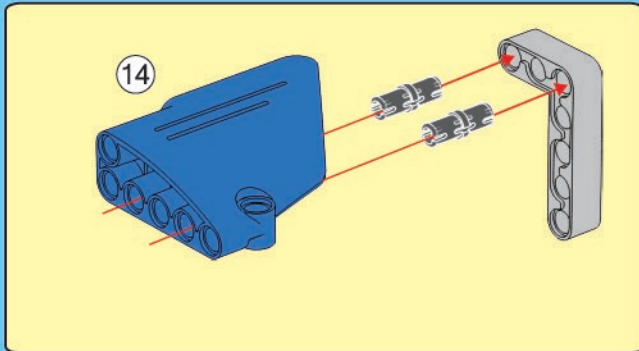

**B25**

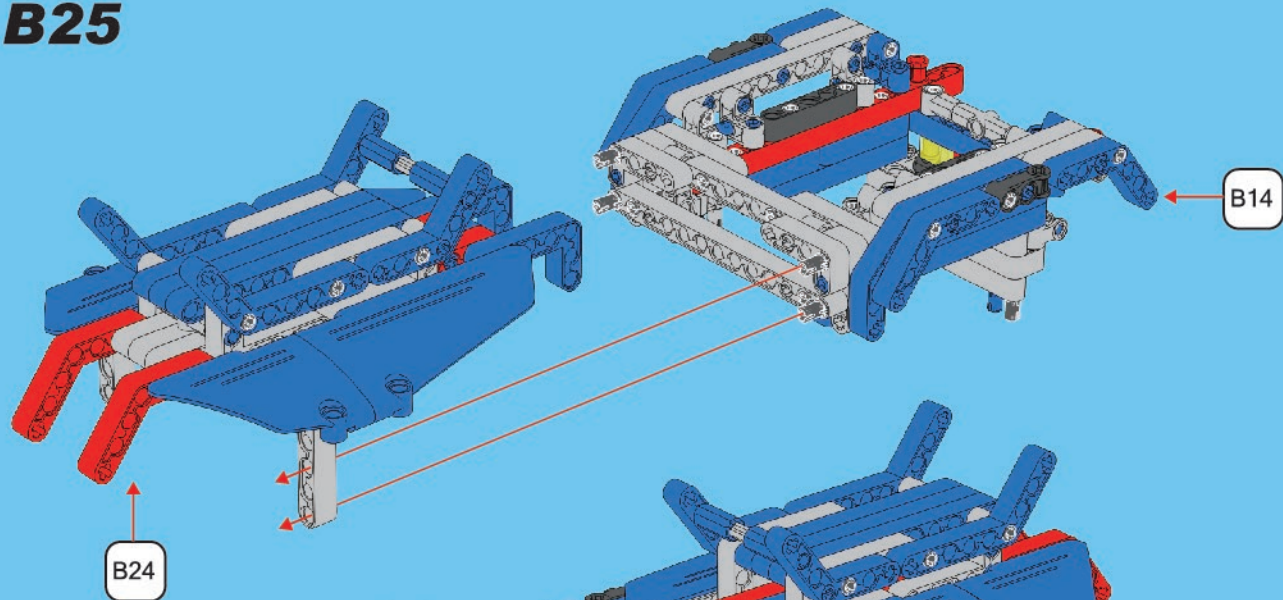

**B26**

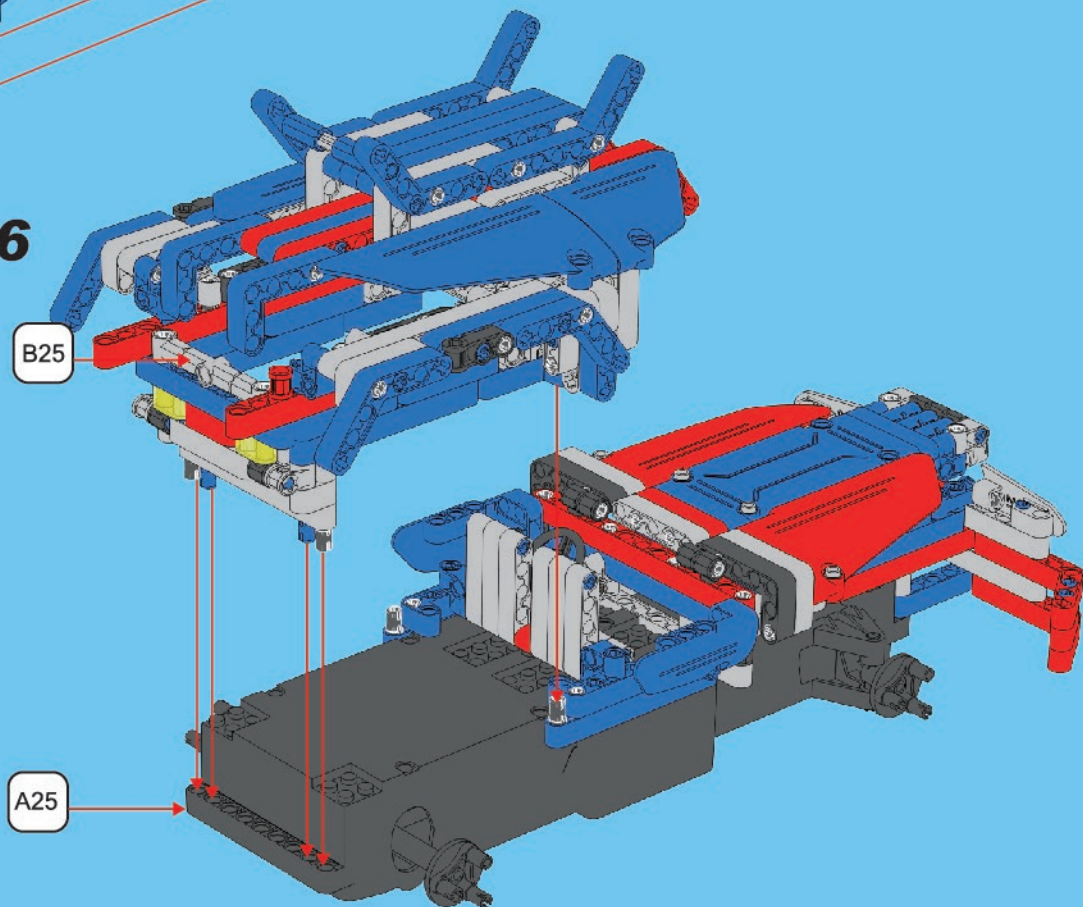



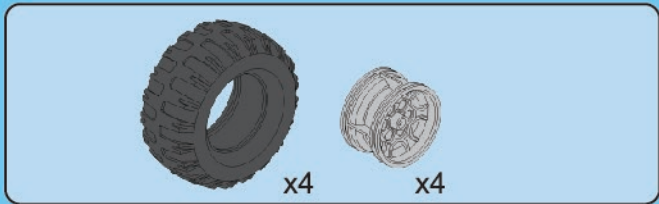

**B27**

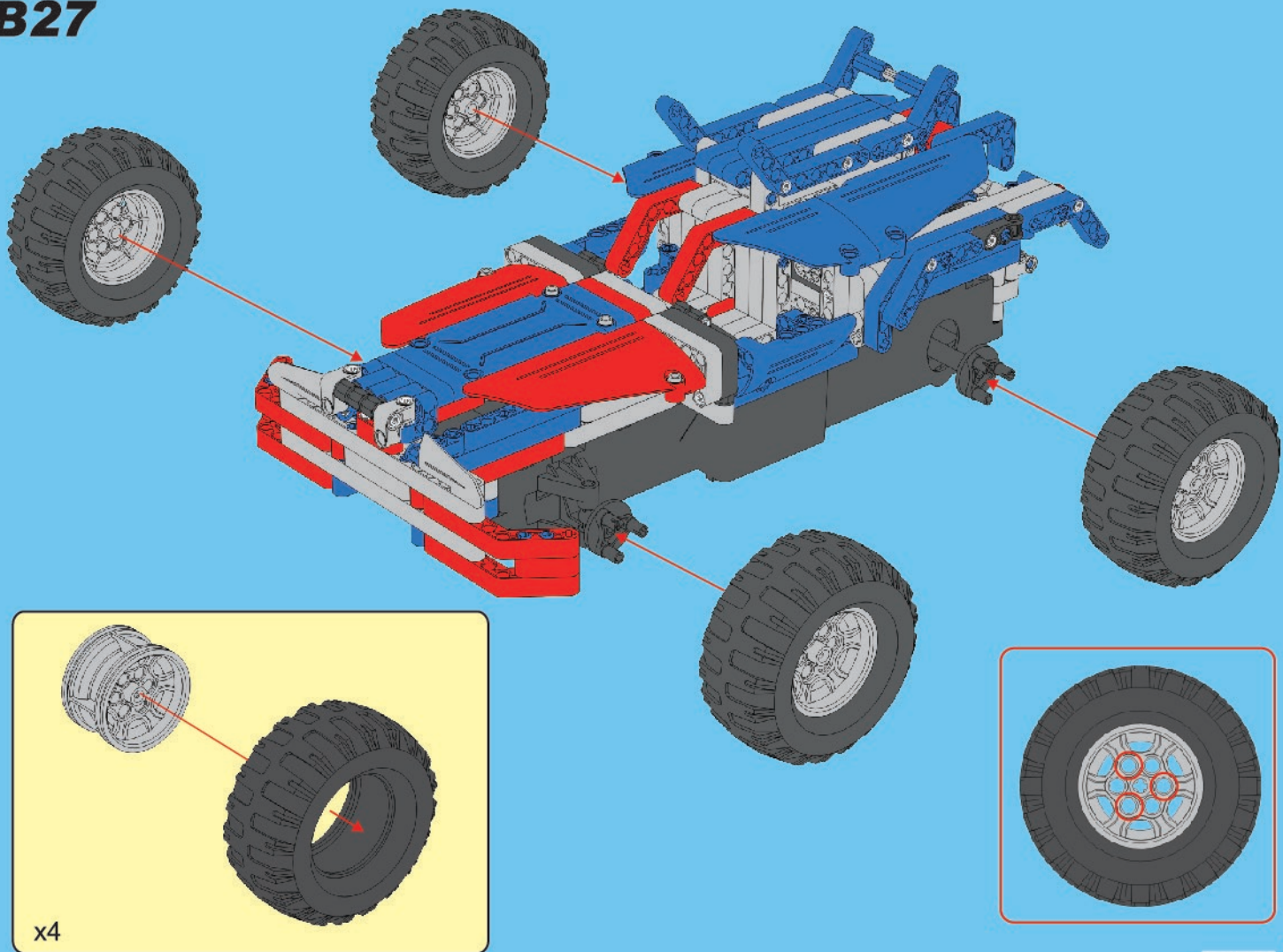

# B28

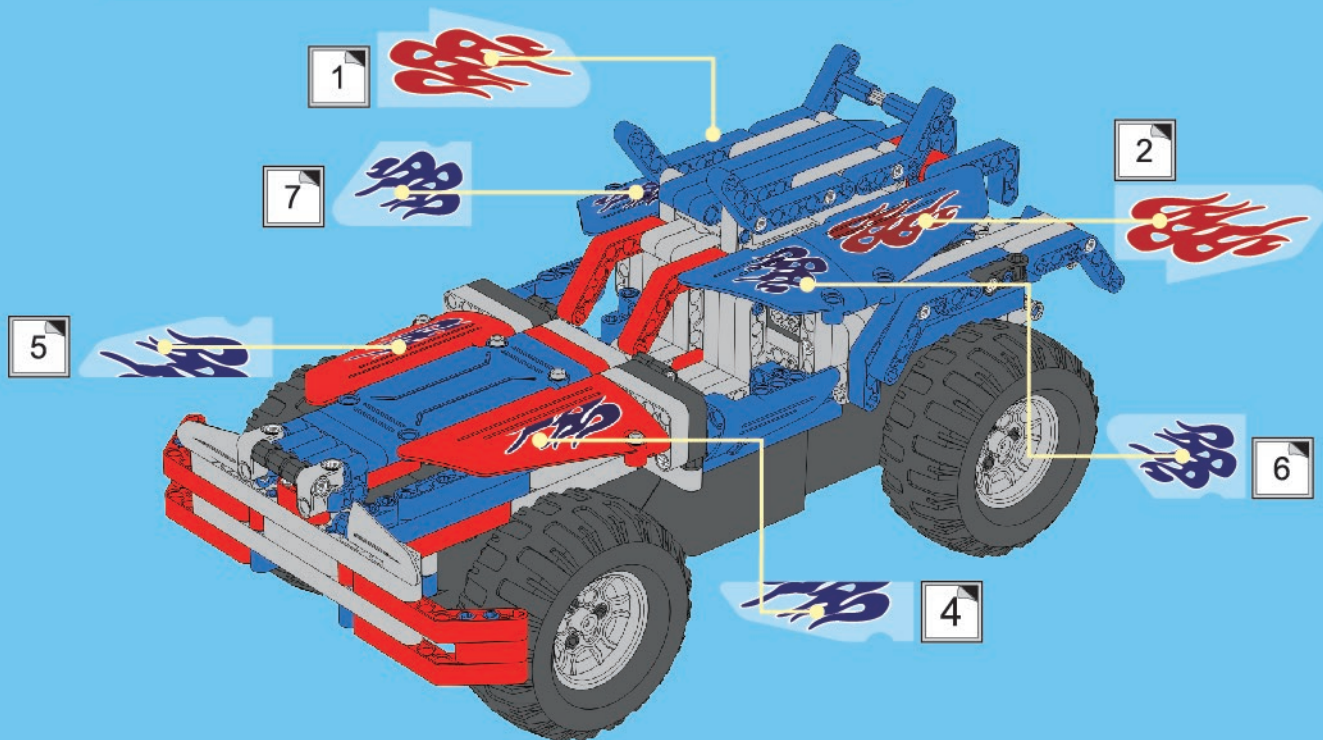
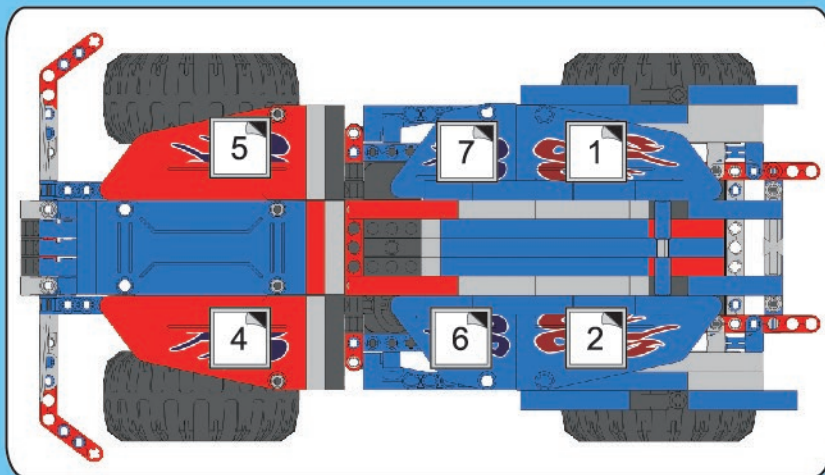

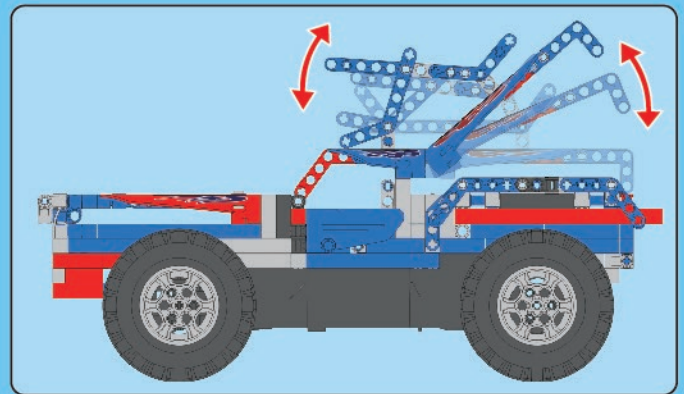
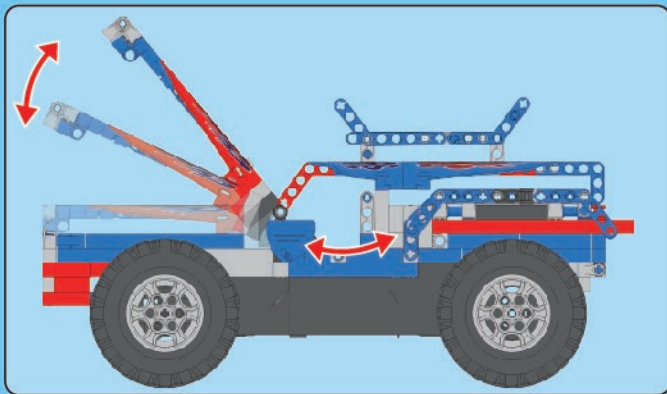
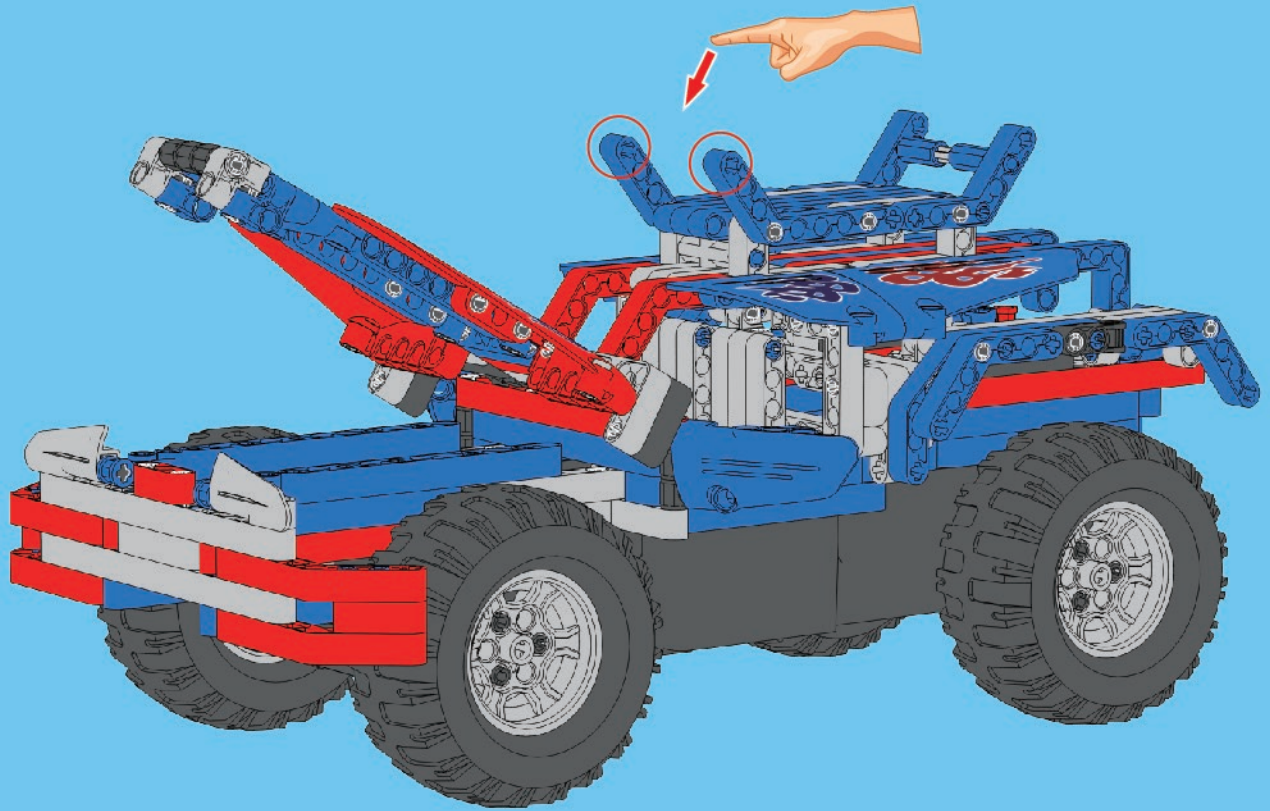

## SAFETY INFORMATION:

- Protect this device and its controller from water, humidity, extreme temperatures, direct sunlight and sources of heat. Do not operate this device in rain, snow or thunderstorm.
- Follow basic safety rules while operating this device. Do not operate this device on streets or highways.
- Pay special attention when operating near pets, young children, the elderly or disabled.
- Do not run this device into furniture, objects or hard surfaces, as this may damage to both the objects and this device.
- Do not touch moving parts of the device while operating. Keep fingers, hair and loose clothing away from the tires, gears and motor when the device is ON.
- Warning! Choking hazard. Keep away from children under the age of 3 years due to small parts. Store small parts out of the reach of children.
- Never try to repair this device yourself. In case of damage, contact with an authorized service point for check-up/repair.
- Not suitable for children under 6 years old.
- The control distance will be reduced if the device or transmitter is not fully charged.
- Clean this device with clean, slightly damp soft cloth. Remember to turn off the device prior to cleaning.
- Use only authorized accessories.
- Do not dispose of this product in fire.
- Turn off the device and remove batteries if the vehicle will not be used for a long time.
- The battery should only be charged under adult supervision.

## INSTRUCTIONS:

- Connect the supplied USB charging cable to battery and USB port (in PC or AC adapter). The red indicator will be on until unplugged from power source. Charge the car battery before first use (first charging may take up to 8 h, next charging will take up to 4 hours). Do not charge the battery for longer than 8 hours.
- Make sure the power switch on the vehicle is in the "OFF" position. Use a screwdriver to open the battery cover underneath the vehicle. Insert the charged car battery into the battery compartment and plug it in. Close the battery compartment and fasten the screw.
- Use a screwdriver to open the battery cover at the back of the remote. Insert 2x AA batteries into the remote controller battery compartment. Note the correct polarization. Close the battery compartment and fasten the screw.
- Turn ON the car and the remote control.
- The indicator on the controller will start to blink and the device is in a state of matching. When the indicator stops blinking and turns off, matching is finished. One remote controller can only be matched and control with one car.
- If the remote controller does not receive any signal from a car for one minute, it will automatically turn to a sleeping state (indicator turns off). To re-activate, please press any key on the remote.



**WARNING: CHOKING HAZARD**

- Small parts not for children under 3 years.

"The Lechpol company declares that product ZAB0107 is consistent with the essential requirements and other relevant provisions of directive 2014/53/UE. The proper declaration for download from [www.lechpol.eu](http://www.lechpol.eu)"

## KWESTIE BEZPIECZEŃSTWA

- Urządzenie oraz pilot należy chronić przed wilgocią, źródłami ciepła, bezpośrednim nasłonecznieniem oraz ekstremalnymi temperaturami. Nie należy obsługiwać tego urządzenia, jeśli nie pozwalają na to warunki atmosferyczne (opady deszczu, śniegu, burza).
- Podczas obsługi urządzenia, należy przestrzegać podstawowych zasad bezpieczeństwa. Nie należy obsługiwać tego urządzenia na ulicach lub autostradach.
- Należy zwrócić szczególną uwagę podczas używania urządzenia w pobliżu zwierząt, dzieci, osób starszych lub niepełnosprawnych.
- Nie należy narażać urządzenia na zderzenia z meblami lub twardymi powierzchniami, ponieważ może to doprowadzić do uszkodzenia tych przedmiotów oraz urządzenia.
- Nie należy dotykać ruchomych części urządzenia. Kiedy urządzenie jest włączone, należy unikać kontaktu palców, włosów i luźnych ubrań z oponami, silnikiem czy częściami ruchomymi.
- Uwaga! Niebezpieczeństwo zakrzuszenia. Ze względu na małe części, należy trzymać urządzenie z dala od dzieci poniżej 3 lat. Małe części należy przechowywać poza zasięgiem dzieci.
- Zabrania się własnoręcznej naprawy sprzętu. W wypadku uszkodzenia, należy skontaktować się z autoryzowanym punktem serwisowym w celu sprawdzenia/naprawy.
- Urządzenie przeznaczone do użytku wyłącznie przez osoby powyżej 6 roku życia.
- Zasięg pilota zostanie zmniejszony, jeśli jego baterie nie są w pełni naładowane.
- Urządzenie należy czyścić za pomocą miękkiej, lekko wilgotnej ściereczki. Urządzenie należy wyłączyć przed czyszczeniem.
- Nie należy używać nieoryginalnych akcesoriów.
- Jeśli urządzenie nie będzie używane przez dłuższy czas, należy wyłączyć urządzenie i wyjąć baterie.
- Akumulator/baterie mogą być ładowane wyłącznie pod nadzorem osób dorosłych.

## OBSŁUGA:

- Należy podłączyć załączony przewód ładowania USB do akumulatora samochodu oraz portu USB (komputera lub ładowarki sieciowej). Czerwony wskaźnik będzie się świecił, aż do odłączenia przewodu ładowania od źródła zasilania. Przed pierwszym użyciem, należy w pełni naładować akumulator samochodu (pierwsze ładowanie może potrwać do 8 h, każde kolejne do 4 h). Nie należy ładować akumulatora dłużej niż 8 godzin.
- Należy się upewnić, że przełącznik zasilania jest w pozycji "OFF" (wył.). Za pomocą śrubokrętu, należy otworzyć klapkę pojemnika na baterie znajdującą się na podwoziu pojazdu. Następnie umieścić i podłączyć naładowany akumulator. Zamknąć pokrywę baterii i przykręcić śrubę.
- Za pomocą śrubokrętu, należy otworzyć pokrywę baterii znajdującej się z tyłu pilota. Następnie, umieścić 2 baterie AA w pojemniku na baterie pilota. Należy zwrócić uwagę na poprawną polaryzację. Zamknąć pokrywę baterii i przykręcić śrubę.
- Przesunąć przycisk zasilania samochodu i pilota na pozycję ON.
- Wskaźnik na pilocie zacznie migać sygnalizując, że urządzenie łączy się z pilotem. Wskaźnik zgasnie, gdy urządzenie połączy się z pilotem. Jeden pilot może być połączony tylko z jednym samochodem jednocześnie.
- Jeśli pilot nie otrzyma żadnego sygnału z samochodu przez minutę, automatycznie przejdzie w tryb uśpienia (wskaźnik się wyłączy). Aby ponownie uruchomić pilota, należy nacisnąć dowolny przycisk na pilocie.