

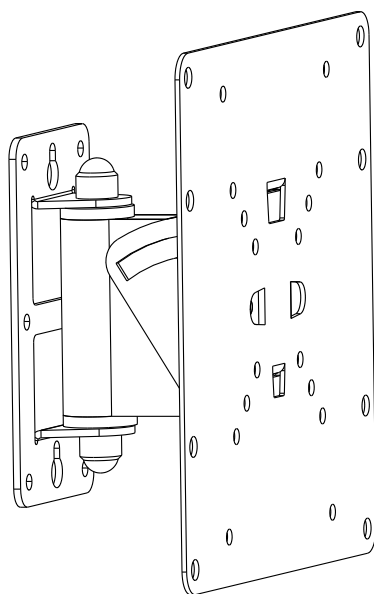

UCH0075 LCD wall mount



User manual



50x50/75x75
100x100/200x100
200x200



30kg
(66lbs)
MAX

English 1-10

Polski 11-22

Română 23-32

Deutsch 33-42

NOTE: Read entire instruction sheet before you start installation and assembly.

WARNING

- Do not begin to installation of the product on you have read and understand the instructions and warnings contained in this Installation Sheet. If you have any question regarding any of the instruction or warning, Please contact your local distributor.
- Please refer to manufacturer's installation guide recommendation for required distance from wall to avoid risk of property damage.
- This product should only be installed by someone of good mechanical aptitude, with experience and basic building, and fully understands.
- Make sure that the supporting surface will safely support the combined load of the equipment and all attached hardware and components.
- Never exceed the Maximum Load Capacity.
- If mounting to wood wall studs, make sure that mounting screws are anchored into the center of the studs. Use of an "edge to edge" stud finder is highly recommended.
- Always use an assistant or mechanical lifting equipment to safely lift and position equipment.
- Tighten screws firmly, but do not over tighten. Over tightening can damage the items, greatly reducing their holding power.
- This products intended for indoor use only. Use of this product outdoors could lead to product failure and personal injury.

Component checklist

IMPORTANT: Ensure you have received all parts against the component checklist prior to installing. If any parts are missing or faulty, telephone the special franchiser for a placement.

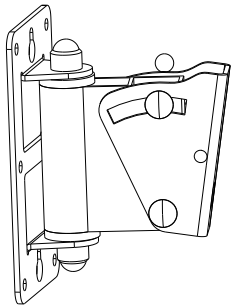

wallmount(x1)
A

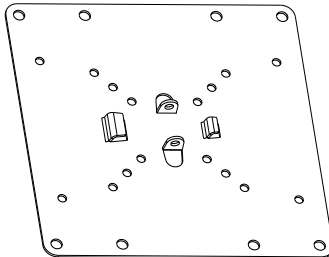

VESAplate(x1)
B



M6x10(x2)
C

Package M



M4x14(x4)
M-A



M5x14(x4)
M-B

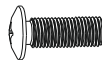

M6x14(x4)
M-C

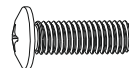

M8x20(x4)
M-D



D5washer(x4)
M-E



D8washer(x4)
M-F



smallspacer(x8)
M-G

Package W



ST5.5x50(x6)
W-A

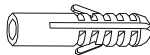

concreteanchor(x6)
W-B



D6washer(x6)
W-C

1a. Mount on Wood Stud Wall

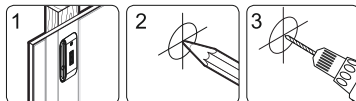
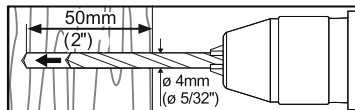

Find and mark the exact location of mounting holes **Drill pilot holes**

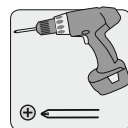
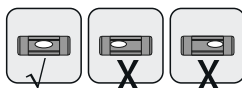

Screw the wall plate onto the wall

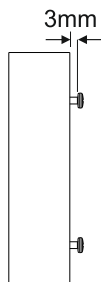
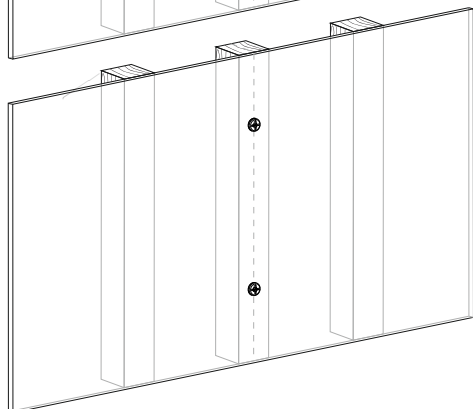
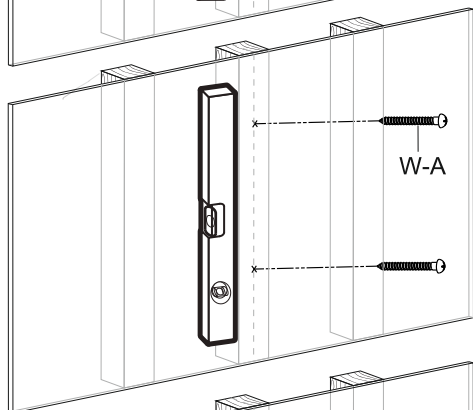
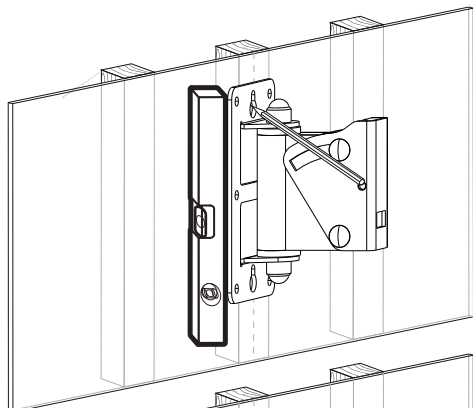

Tighten both screws spacing 3mm to wall.

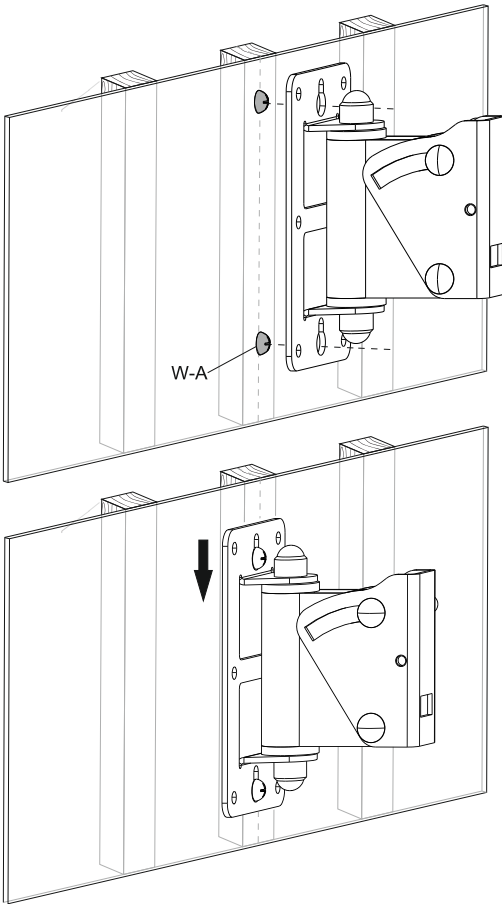
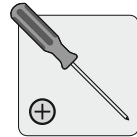

Align both holes of wall plate to screws in wall and lower the wall plate until both screws are seated in upper area of tear-drop mounting holes.

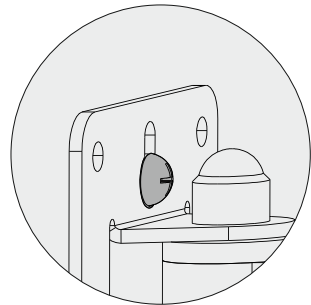

Level the wall plate, tighten all screws to secure it.

WARNING

- Make sure that mounting screws are anchored into the center of the studs. Use of a stud finder is highly recommended.
- Installers are responsible to provide hardware for other types of mounting situations.
- Installers must verify that the supporting surface will safely support the combined load of the equipment and all attached hardware and components.

1b. Mount on Solid Brick and Concrete Block

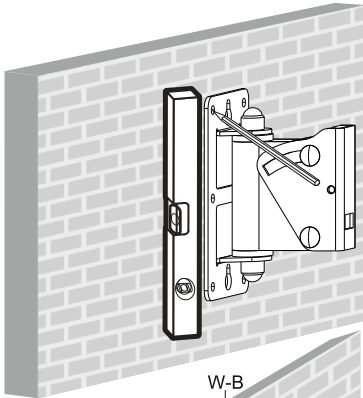
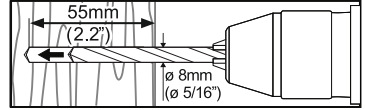
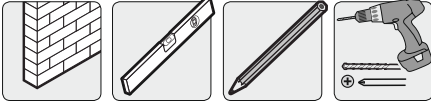

1
Mark the exact location of mounting holes

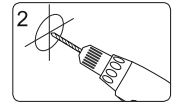

2
Drill pilot holes

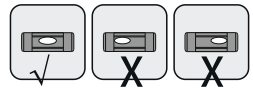
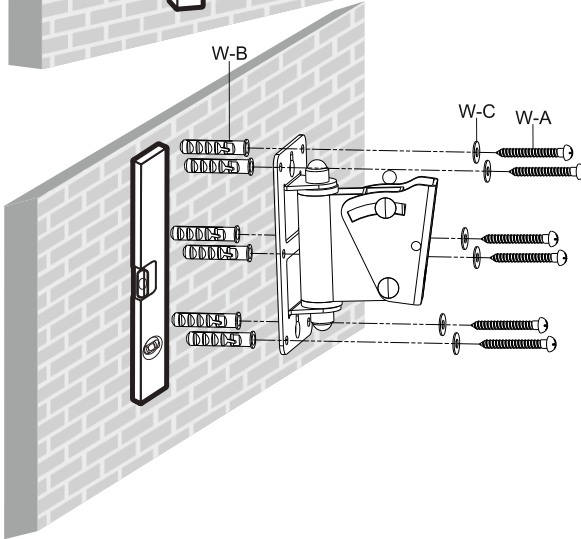

Screw the wall plate onto the wall

WARNING

- When installing wall mounts on cinder block, verify the actual concrete thickness is at least 1-3/8" (35mm) for using the concrete anchors. Do not drill into mortar joints! Be sure to mount in a solid part of the block, generally 1" (25mm) minimum from the side of the block. It is suggested electric drill on slow setting is used to drill the hole instead of a hammer drill to avoid breaking out the back of the hole when entering a void or cavity.
- Installers must verify that the supporting surface will safely support the combined load of the equipment and all attached hardware and components.

2. Install the VESA Plate

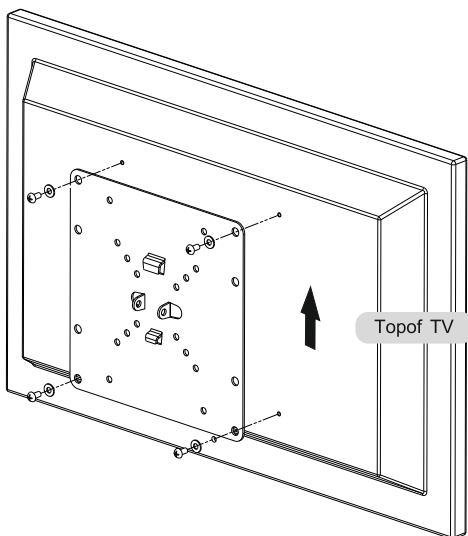
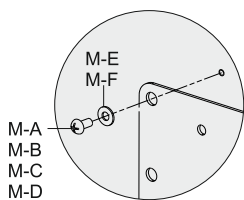
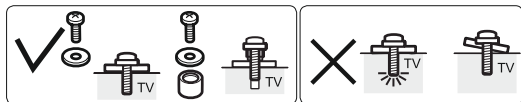

or

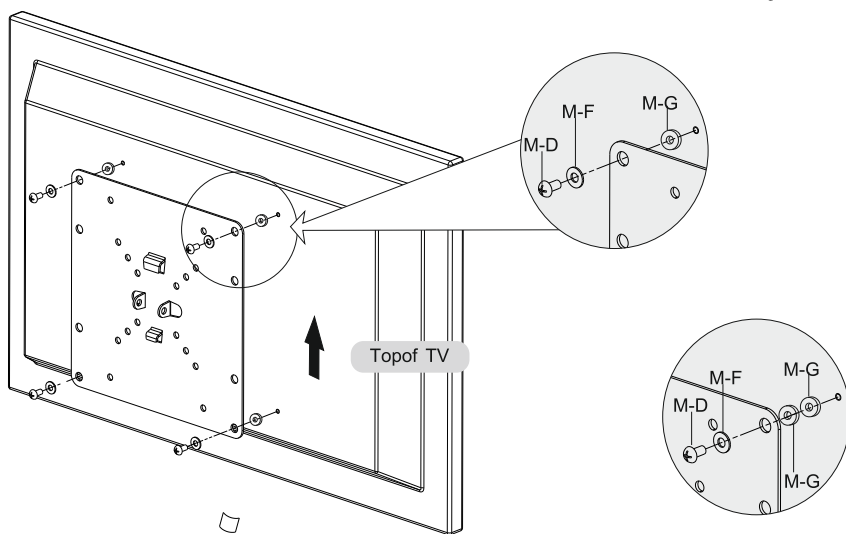

Screw VESA plate onto the display.



Tighten all screws but do not over tighten.

3. Hang the display onto the Wall Mount

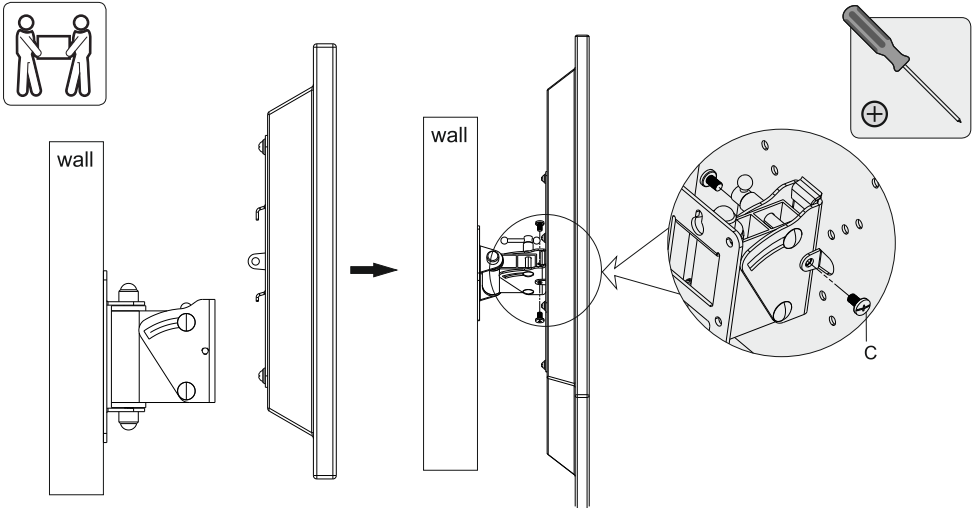

Hook the VESA plate(attached the display) onto the wall mount and tighten the screws to secure it.

4. Adjustment

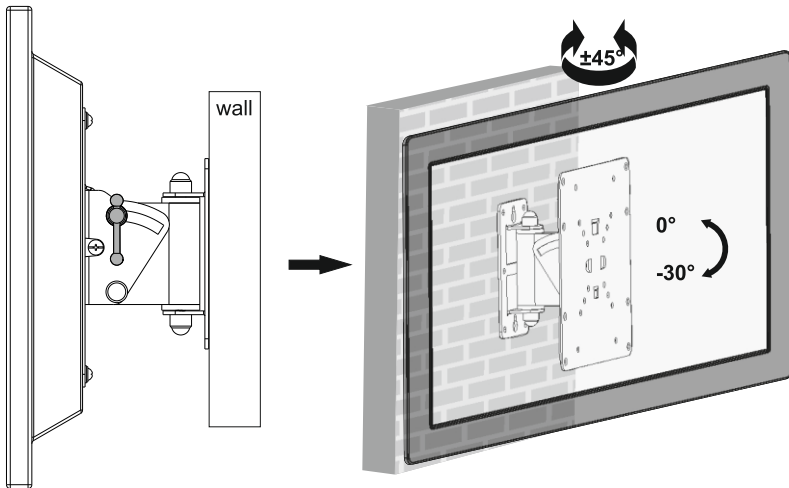

Loose the adjusting knob and adjust to the desired angle, then tighten it.

Maintenance

Maintenance

- Check that the bracket is secure and safe to use at regular intervals(at least every three months).
- Please contact your dealer if you have any questions.

English



Correct Disposal of This Product (Waste Electrical & Electronic Equipment)

(Applicable in the European Union and other European countries with separate collection systems)

This marking shown on the product or its literature, indicates that it should not be disposed with other household wastes at the end of its working life. To prevent possible harm to the environment or human health from uncontrolled waste disposal, please separate this from other types of wastes and recycle it responsibly to promote the sustainable reuse of material resources.

Household users should contact either the retailer where they purchased this product, or their local government office, for details of where and how they can take this item for environmentally safe recycling.

Business users should contact their supplier and check the terms and conditions of the purchase contract. This product should not be mixed with other commercial wastes for disposal.



Made in China for LECHPOL Zbigniew Leszek, Miętne, 1 Garwolińska Street 08-400 Garwolin.



UCH0075

Uchwyt ścienny do TV

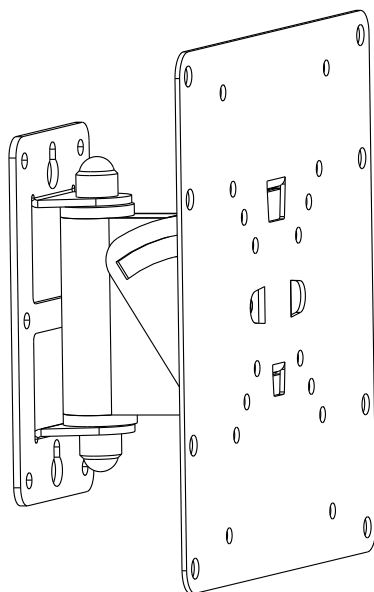

Instrukcja obsługi



50x50/75x75
100x100/200x100
200x200



30kg
(66lbs)
MAX

English 1-10

Polski 11-22

Română 23-32

Deutsch 33-42

UWAGA: Przed rozpoczęciem montażu, należy przeczytać instrukcję obsługi.

UWAGA

- Przed przystąpieniem do montażu, należy dokładnie przeczytać całą instrukcję obsługi. W przypadku jakichkolwiek wątpliwości, należy skontaktować się z lokalnym dystrybutorem.
- Należy przestrzegać zaleceń producenta odnośnie miejsca i sposobu montażu.
- Instalacja uchwyty powinna być przeprowadzona przez wykwalifikowaną osobę cechującą się dobrymi umiejętnościami mechanicznymi, znającą konstrukcję budynku oraz dobrze rozumiejącą instrukcję obsługi.
- Należy upewnić się, że powierzchnia nośna wytrzyma obciążenie uchwyty wraz z podłączonymi do niego urządzeniami.
- Nie należy przekraczać dopuszczalnego maksymalnego obciążenia.
- Podczas przymocowywania telewizora, należy skorzystać z pomocy drugiej osoby.
- Śruby należy dokręcić mocno, lecz nie za mocno. Zbyt mocne dokręcenie może doprowadzić do zniszczenia lub osłabienia gwintu.
- Produkt przeznaczony jest do użytku wewnątrz pomieszczeń.

Zawartość opakowania

WAŻNE: Należy się upewnić, że w zestawie są wszystkie elementy wymienione na liście. Jeżeli brakuje jakiegokolwiek części lub jest ona uszkodzona, należy skontaktować się z dystrybutorem.

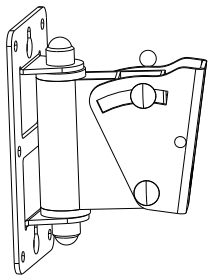

uchwyt (x1)
A

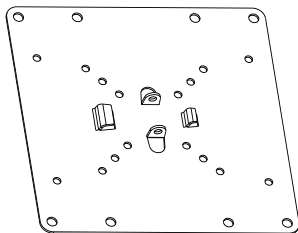

wspornik (x1)
B



M6x10(x2)
C

Opakowanie M



M4x14(x4)
M-A



M5x14(x4)
M-B

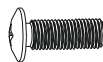

M6x14(x4)
M-C

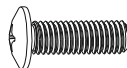

M8x20(x4)
M-D



podkładka D5 (x4)
M-E



podkładka D8 (x4)
M-F



dystans (x8)
M-G

Opakowanie W



Śruba ST5.5x50 (x6)
W-A



podkładka D6 (x6)
W-B



kołek rozporowy (x6)
W-B

1a. Montaż do ściany drewnianej

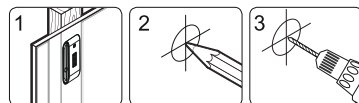
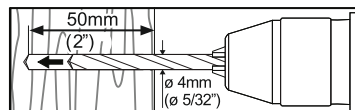

Należy dokładnie zaznaczyć i wywiercić otwory montażowe.

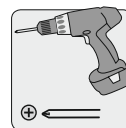
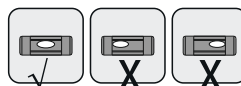

Za pomocą śrub należy przykręcić uchwyt do ściany.

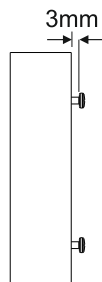
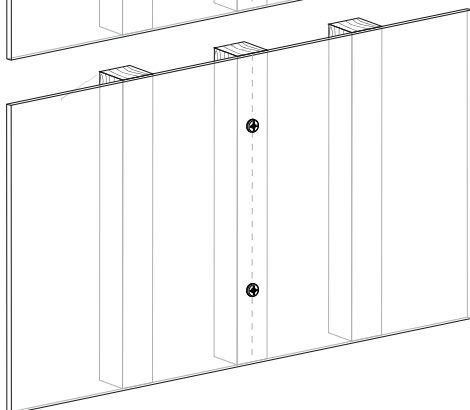
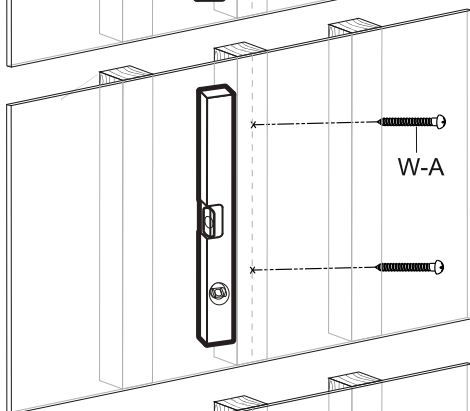
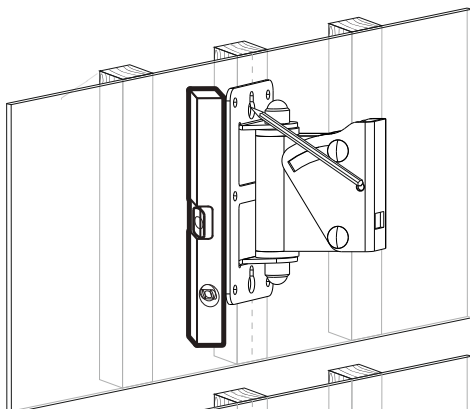

Śrubę należy przykręcić w taki sposób, aby pozostał dystans 3mm od ściany.

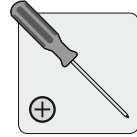
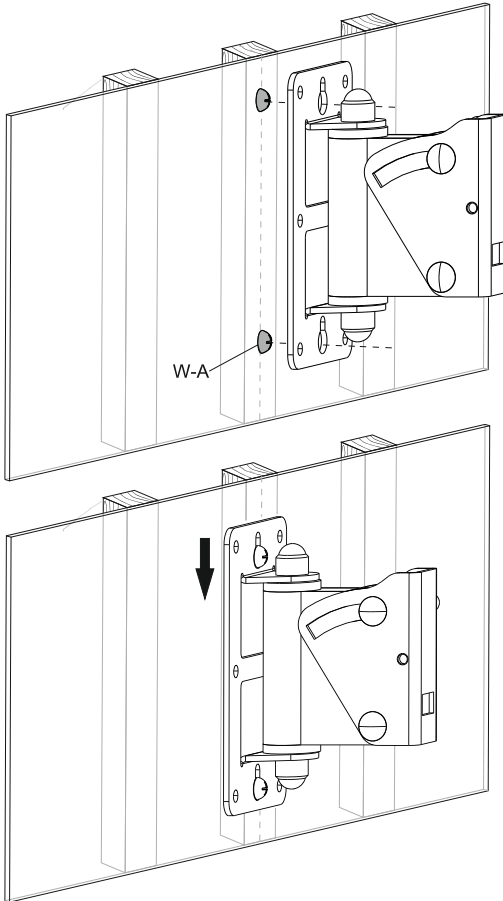

Uchwyt należy nałożyć na wystające śruby i opuścić go w dół (tak aby śruby weszły w rowki zabezpieczające odpadnięcie uchwytu).

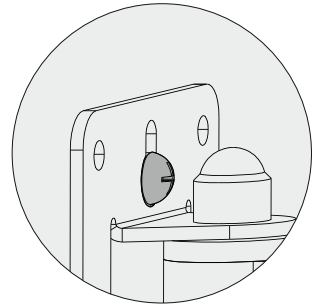

Po założeniu uchwytu, należy dokręcić śruby.

UWAGA

- Należy się upewnić, że powierzchnia nośna wytrzyma obciążenie uchwytu wraz z podłączonymi urządzeniami.
- Jeżeli wymagany jest inny typ instalacji niż opisany, to instalator odpowiada za dostarczenie potrzebnego sprzętu.
- Śruby należy dokręcić mocno, lecz nie zbyt mocno. Zbyt mocne dokręcenie może doprowadzić do ich zniszczenia lub osłabienia.

1b. Montaż do ściany betonowej

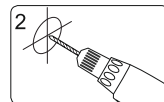
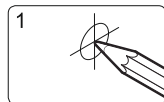
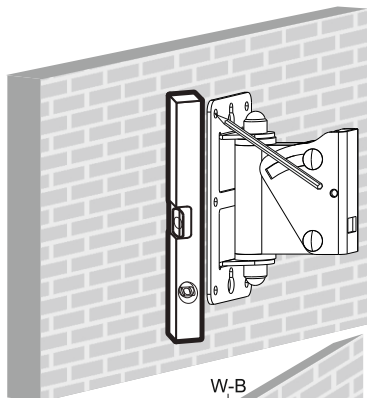
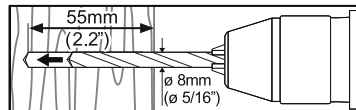
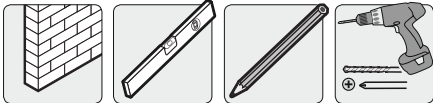

Należy dokładnie zaznaczyć i wywiercić otwory montażowe.

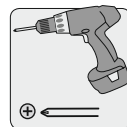
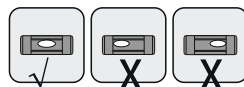
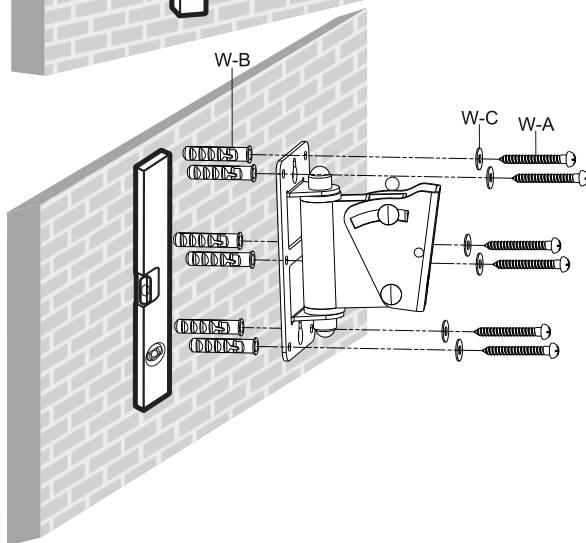

Za pomocą śrub należy przykręcić uchwyt do ściany.

⚠ UWAGA

- Nie należy wiercić otworów w zaprawie murarskiej. Kołki rozporowe należy zamontować w stałej części bloku, przynajmniej 1cm od brzegu. Zalecane jest używanie wiertarki elektrycznej z ustawionymi wolnymi obrotami. Nie jest wskazane używanie wiertarki udarowej.
- Należy się upewnić, że powierzchnia nośna wytrzyma obciążenie uchwytu wraz z podłączonymi do niego urządzeniami.

2. Montaż wspornika

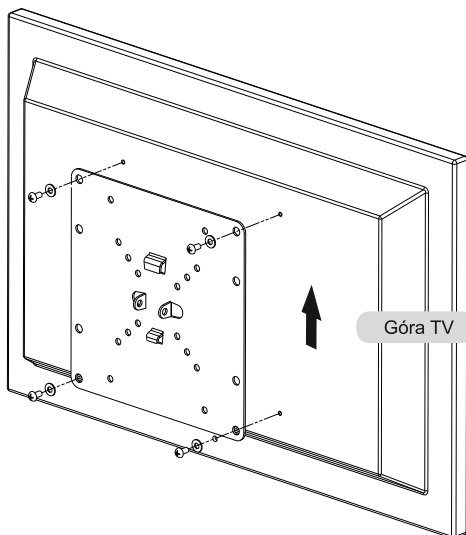
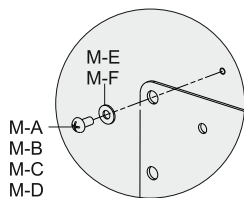
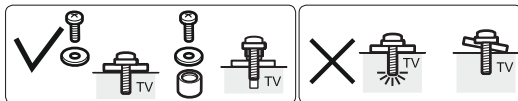

lub

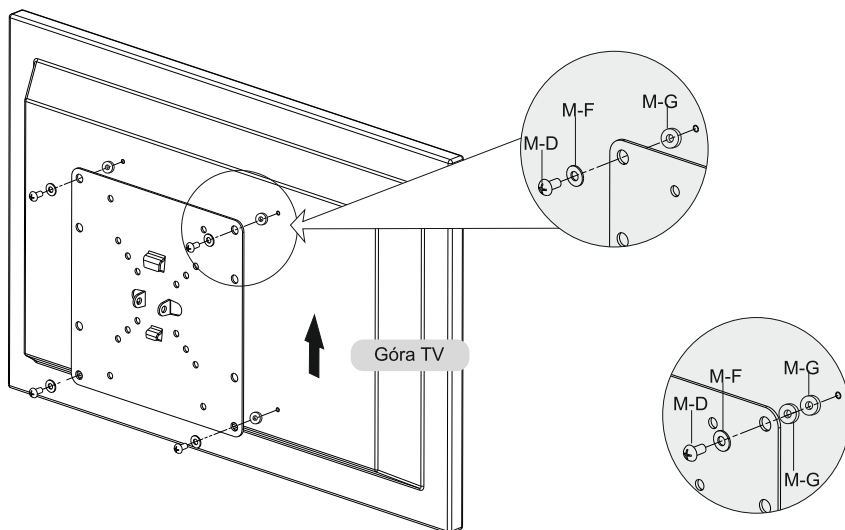

Uchwyt należy przykręcić do telewizora używając odpowiednich śrub i podkładek.



Przykręcenie śruby z nadmierną siłą może spowodować uszkodzenie gwintu.

3. Montaż telewizora ze wspornikiem do uchwytu

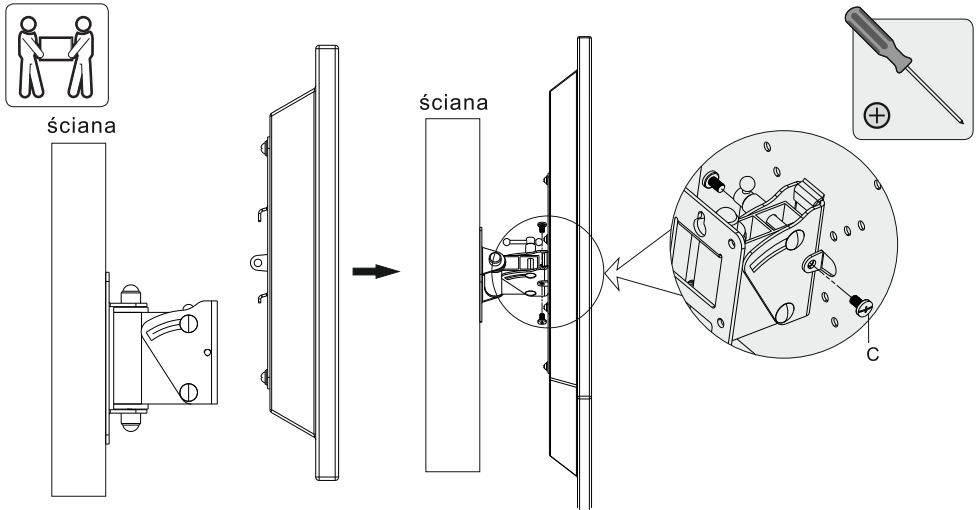

Telewizor ze wspornikiem należy zawiesić na uchwycie, następnie należy przykręcić śruby zabezpieczające.

4. Regulacja

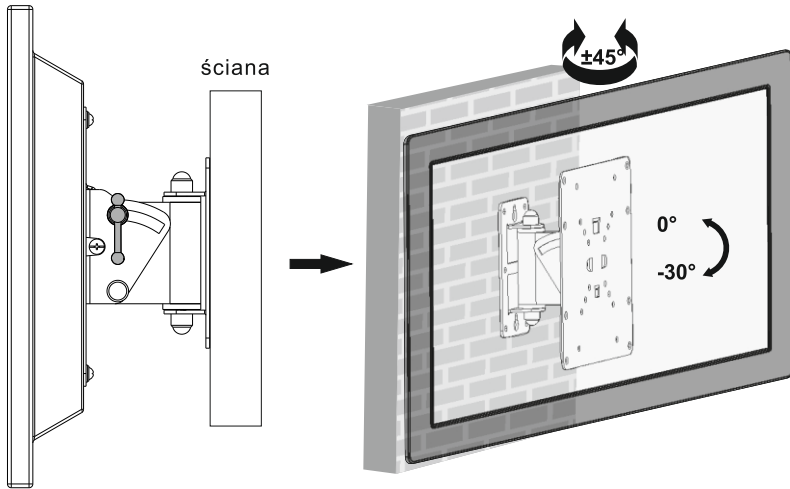

Za pomocą pokrętła regulacji należy dostosować ekran do żądanej pozycji.

Użytkowanie

- Po zawieszeniu telewizora, należy się upewnić że jest on dobrze przymocowany. Należy okresowo (np. co kilka miesięcy) sprawdzać, czy śruby i inne elementy nie poluzowały się i są solidnie zamocowane.
- Jeżeli istnieją jakiegokolwiek wątpliwości lub problemy odnośnie montażu, należy skontaktować się z lokalnym dystrybutorem.

Poland



***Prawidłowe usuwanie produktu
(zużyty sprzęt elektryczny i elektroniczny)***

Oznaczenie umieszczone na produkcie lub w odnoszących się do niego tekstach wskazuje, że po upływie okresu użytkowania, nie należy usuwać go z innymi odpadami pochodzącymi z gospodarstw domowych. Aby uniknąć szkodliwego wpływu na środowisko naturalne i zdrowie ludzi wskutek niekontrolowanego usuwania odpadów, prosimy o oddzielenie produktu od innego typu odpadów oraz odpowiedzialny recykling w celu promowania ponownego użycia zasobów materialnych jako stałej praktyki.

W celu uzyskania informacji na temat miejsca i sposobu bezpiecznego dla środowiska recyklingu tego produktu użytkownicy w gospodarstwach domowych powinni skontaktować się z punktem sprzedaży detalicznej, w którym dokonali zakupu produkt, lub z organem władz lokalnych.

Użytkownicy w firmach powinni skontaktować się ze swoim dostawcą i sprawdzić warunki umowy zakupu. Produktu nie należy usuwać razem z innymi odpadami komunalnymi.



Wyprodukowano w CHRL dla LECHPOL Zbigniew Leszek, Miętne ul. Garwolińska 1, 08-400 Garwolin.



UCH0075

Suport TV LCD LED

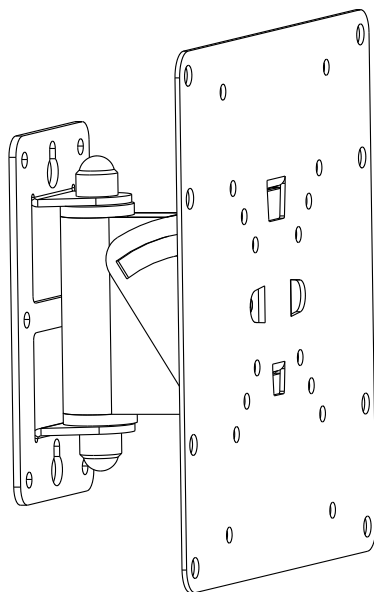

English 1-10

Polski 11-22

Română 23-32

Deutsch 33-42

Manual de utilizare



50x50/75x75
100x100/200x100
200x200



30kg
(66lbs)
MAX

Inainte de instalare



- Nu incepeti instalarea suportului decat dupa ce ati citit si inteles instructiunile de montare.
- Respectati recomandarile din acest manual de instalare cu privire la distanta fata de perete necesara la montarea suportului.
- Instalarea suportului este recomandata sa fie executata de catre personal calificat.
- Verificati daca peretele este poate suporta sarcinile maxime admisibile de catre suport.
- Nu depasiti sarcina maxima admisibila a suportului.
- Asigurati-va ca suruburile de fixare pentru diblu sa fie centrate exact in mijlocul gaurilor de pozitionare de pe suport (eventual utilizati un dispozitiv de centrare) in momentul strangerii acestora.
- Strangeti suruburile ferm dar nu exagerati. Strangerea prea puternica a acestora poate distruge partile componente ale suportului
- Solicitati ajutorul altei persoane pentru pozitionarea aparatului pe suport.
- Suportul este destinat utilizarii in interior. Nu utilizati suportul in exterior pentru a evita riscul producerii de accidente sau defectarea produsului.

Continut colet

Asigurati-va ca ati primit toate componentele necesare montarii suportului inainte de instalarea acestuia, urmarind figurile urmatoare:

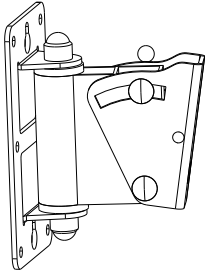

placa de baza (x1)
A

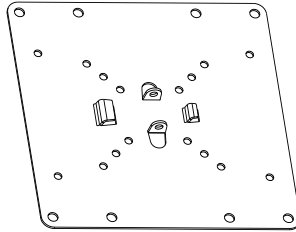

adaptor (x1)
B



M6x10(x2)
C

Pachet M



M4x14(x4)
M-A



M5x14(x4)
M-B



M6x14(x4)
M-C

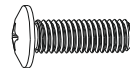

M8x20(x4)
M-D



D5 saiba (x4)
M-E



D8 saiba (x4)
M-F



saiba (x8)
M-G

Pachet W



ST5.5x50 (x6)
W-A



D6 saiba (x6)
W-C

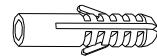

diblu beton (x6)
W-B

1a. Montarea suportului pe perete de lemn

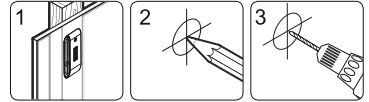
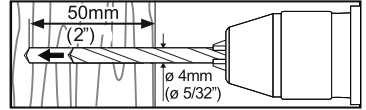

Gasiti si marcati locatia exacta a orificiilor de montare utilizand placa de baza ca sablon. Verificati intai ca aceasta sa fie orizontala, urmarind nivelul cu bula de aer. Efectuati gaurile de montare

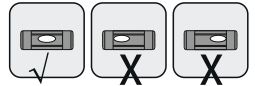

Insurubati placa de baza pe perete.

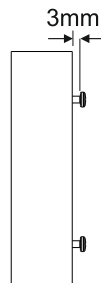
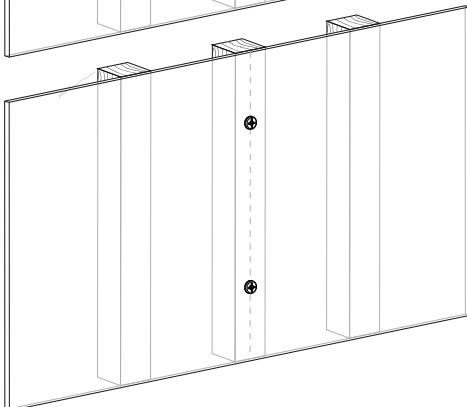
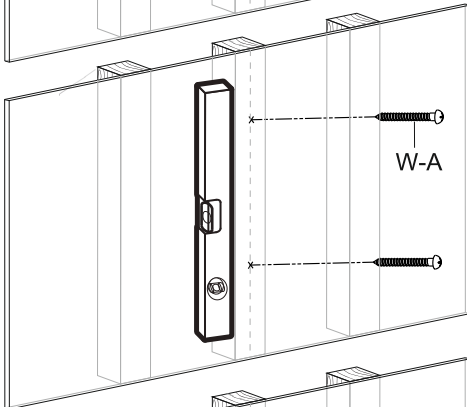
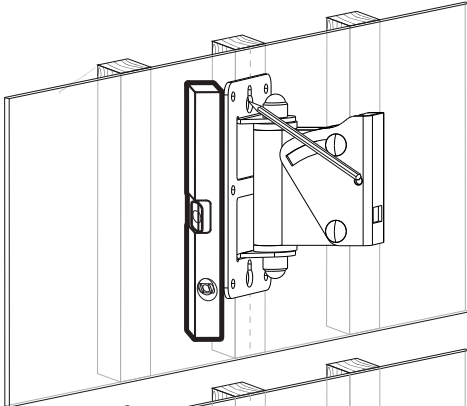

Strangeti ambele suruburi la o distanta de 3mm de perete.

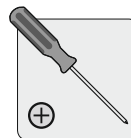
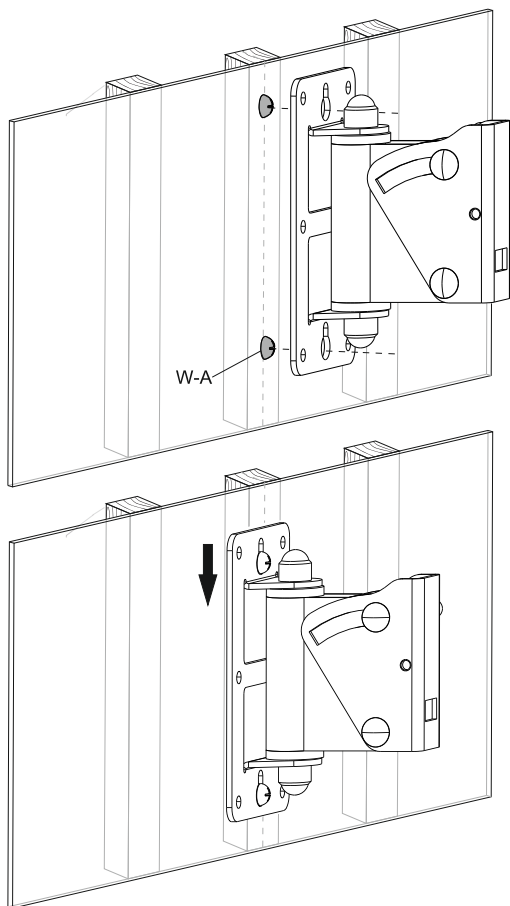

Aliniati ambele gauri ale placii de baza la suruburile din perete si lasati in jos placa de baza pana cand ambele suruburi intra in locul din partea de sus a orificiilor de montare.

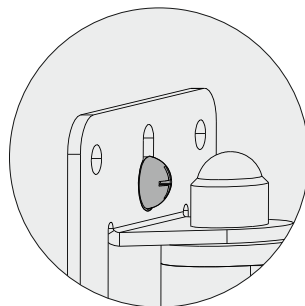

Indreptati placa de baza si strangeti toate suruburile pentru a fixa placa.



AVERTISMENT

- Asigurati-va ca suruburile de montare sunt bine pozitionate si stranse. Folosirea unui detector de metale este recomandata atunci cand efectuati gaurile de prindere.
- Cei care instaleaza sunt responsabili cu furnizarea de echipament pentru alte tipuri de situatii de montare.
- Instalatorii trebuie sa verifice ca suprafata de sprijin sa suporte in conditii de siguranta sarcina echipamentelor si toate componentele atasate..

1b. Montarea suportului pe perete de beton

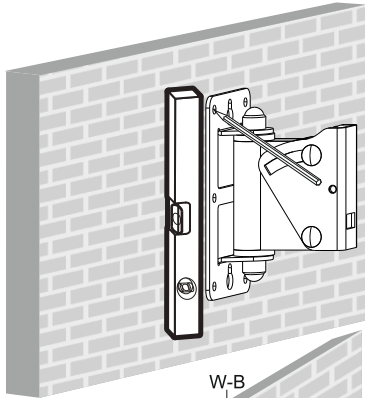
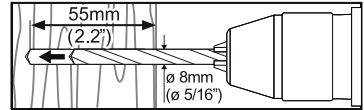
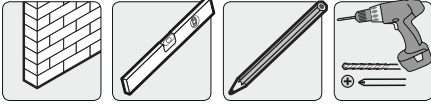

1
**Marcați locația
 exactă a orificiilor
 de montare**

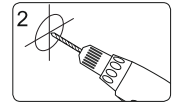

2
Efectuați gaurile de ghidare

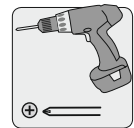
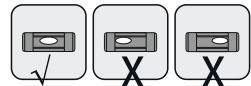
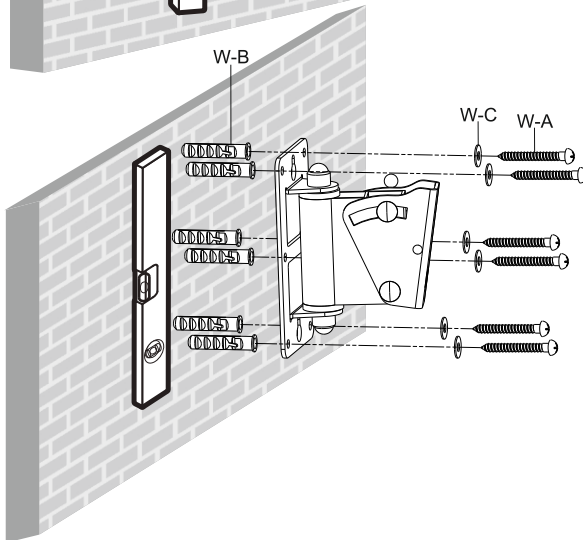

**Însurubiți placa
 de bază pe perete**



AVERTISMENT

- La instalarea suportului pe perete de beton, verificați ca grosimea betonului să fie de cel puțin 1-3/8" (35mm) pentru a putea folosi ancorele de beton. Asigurați-va că montați pe o suprafață solidă, în general lăsând o distanță de 1" (25mm) față de marginea peretelui de beton. Utilizați mașina de găurit cu atenție, pentru a evita spargerea peretelui atunci când există un spațiu gol sau o cavitate.
- Instalatorii trebuie să verifice că suprafața de sprijin va suporta în condiții de siguranță sarcina echipamentelor și toate componentele atașate.

2. Instalarea placii VESA

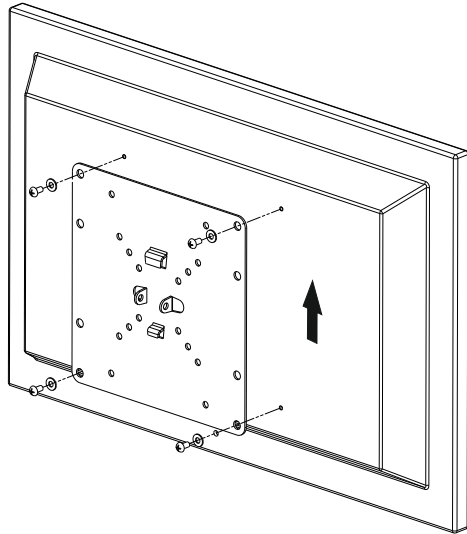
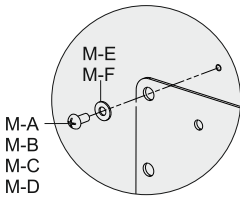
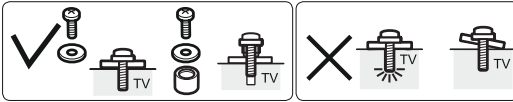

or

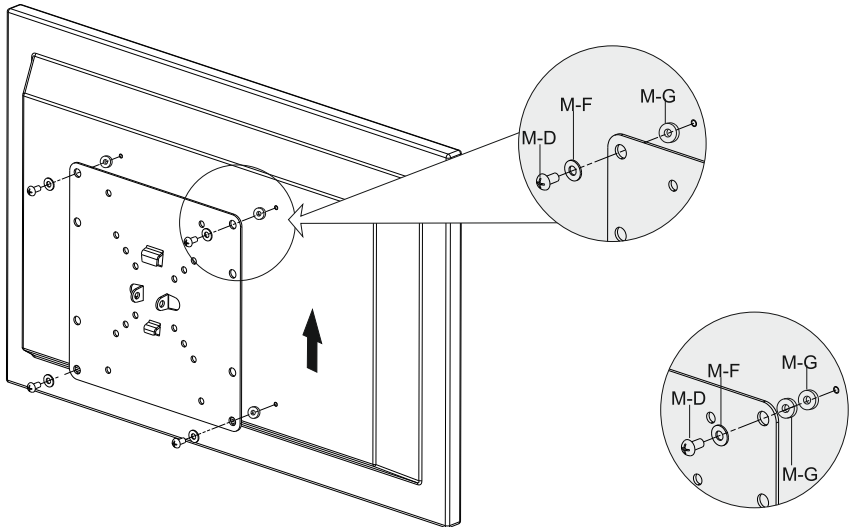

Insurubati placa VESA pe partea din spate a ecranului.



Strangeti toate suruburile dar nu strangeti prea tare.

3. Fixarea televizorului pe perete

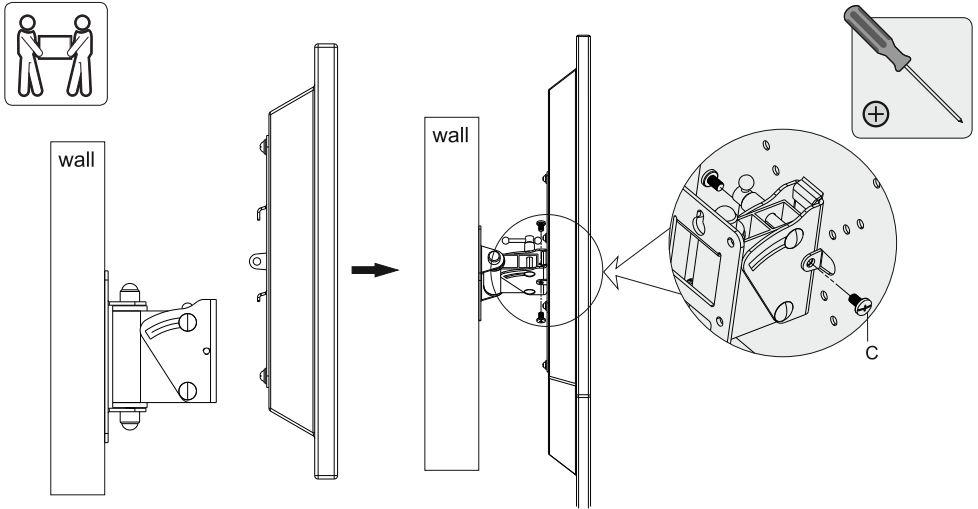

Agatati placa VESA (atasata televizorului) pe suportul de perete si strangeti suruburile pentru fixare.

4. Reglare

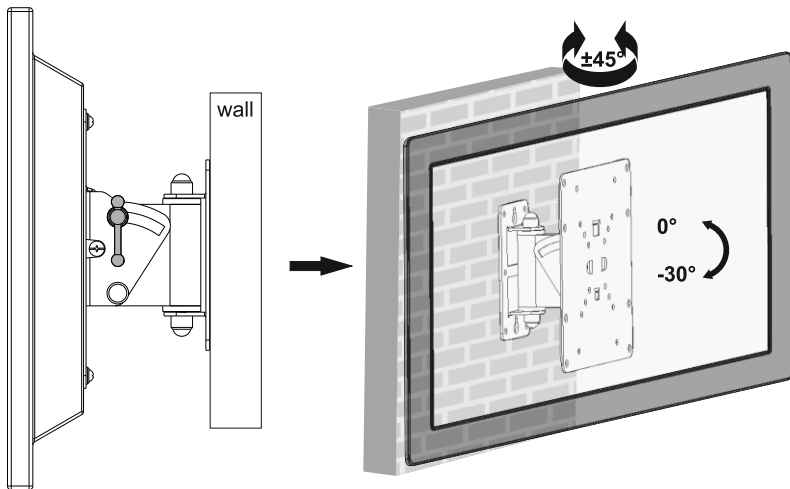

Desfaceti butonul de reglare si reglati la unghiul dorit, apoi strangeti la loc.

Intretinere

Intretinere

- Verificati ca suportul sa fie fixat la intervale regulate (cel putin o data la 3 luni)
- Va rugam sa contactati furnizorul in cazul in care aveti intrebari.

Romania



Reciclarea corecta a acestui produs (reziduuri provenind din aparatura electrica si electronica)

Marcajale de pe acest produs sau mentionate in instructiunile sale de folosire indica faptul ca produsul nu trebuie aruncat impreuna cu alte reziduuri din gospodarie atunci cand nu mai este in stare de functionare. Pentru a preveni posibile efecte daunatoare asupra mediului inconjurator sau asupra sanatatii oamenilor datorate evacuarii necontrolate a reziduurilor, va rugam sa separati acest produs de alte tipuri de reziduuri si sa-l reciclati in mod responsabil pentru a promova re folosirea resurselor materiale.

Utilizatorii casnici sunt rugati sa ia legatura fie cu distribuitorul de la care au achizitionat acest produs, fie cu autoritatile locale, pentru a primi informatii cu privire la locul si modul in care pot depozita acest produs in vederea reciclarii sale ecologice.

Utilizatori instititionali sunt rugati sa ia legatura cu furnizorul si sa verifice conditiile stipulate in contractul de vanzare. Acest produs nu trebuie amestecat cu alte reziduuri de natura comerciala.



Produs in RPC pentru Lechpol Electronic SRL, Republicii nr. 5, Resita, CS , ROMANIA.

UCH0075 LCD TV Wandhalterung

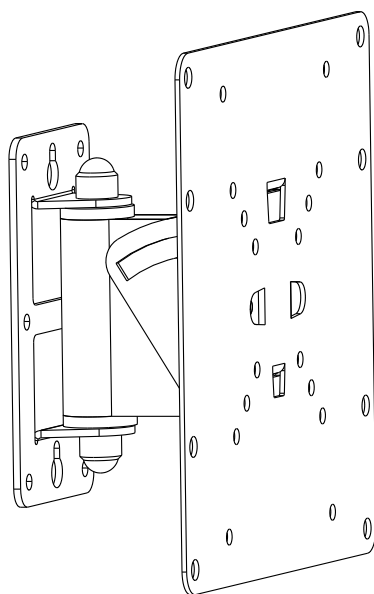

Bedienungsanleitung



50x50/75x75
100x100/200x100
200x200



42"
MAX



30kg
(66lbs)
MAX

English 1-10

Polski 11-22

Română 23-32

Deutsch 33-42

Vor Der Montage



- Beginnen Sie mit der Montage erst nachdem Sie die Montageanweisungen gelesen und verstanden haben.
- Befolgen Sie die Empfehlungen des Handbuchs bezüglich des benötigten Abstandes zwischen Wand und Halterung.
- Es wird empfohlen, die Montage von qualifiziertem Personal durchzuführen.
- Prüfen Sie, ob die Wand die Belastung der Halterung aushält.
- Überschreiten Sie nicht die maximal zulässige Last der Halterung.
- Bei einer Montage auf einer Holzwand achten Sie darauf, dass die Befestigungsschrauben in der Mitte der Pfosten zentriert werden (eventuell benutzen Sie eine Zentriervorrichtung).
- Ziehen Sie die Schrauben fest an, aber ziehen Sie die Schrauben nicht übermäßig an. Zu festes Anziehen der Schrauben, kann diese beschädigen und vermindert dadurch ihre Haltkraft.
- Bitten Sie eine andere Person um Hilfe für die Positionierung des Gerätes in der Halterung.
- Die Halterung ist nur für den Innenraum bestimmt. Verwenden Sie die Halterung nicht im Außenbereich um das Risiko von Verletzungen oder Beschädigungen am Produkt zu vermeiden.

Inhalt Der Packung

Vor der Montage Stellen Sie sicher, dass alle notwendigen Einzelteile vorhanden sind anhand folgender Abbildungen.

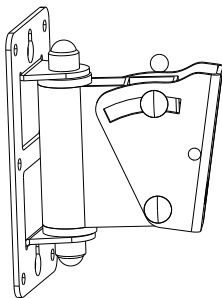

Basisplatte (x1)
A

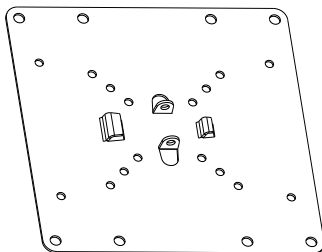

Halterung (x1)
B



M6x10(x2)
C

Paket M



M4x14(x4)
M-A



M5x14(x4)
M-B

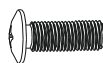

M6x14(x4)
M-C

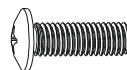

M8x20(x4)
M-D



D5 Scheibe (x4)
M-E



D8 Scheibe (x4)
M-F



Scheibe (x8)
M-G

Paket W



Holzschraube ST5.5x50 (x6)
W-A



D6 Scheibe (x6)
W-C



Betondübel (x6)
W-B

1a. Montage An Einer Holzwand

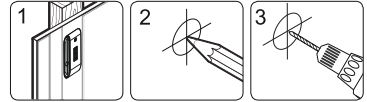
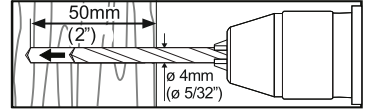

Finden und markieren Löcher vorbohren
Sie die exakte Position der Montagelöcher

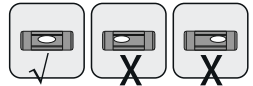

Schrauben Sie
Wandplatte an
die Wand

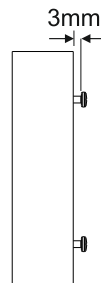
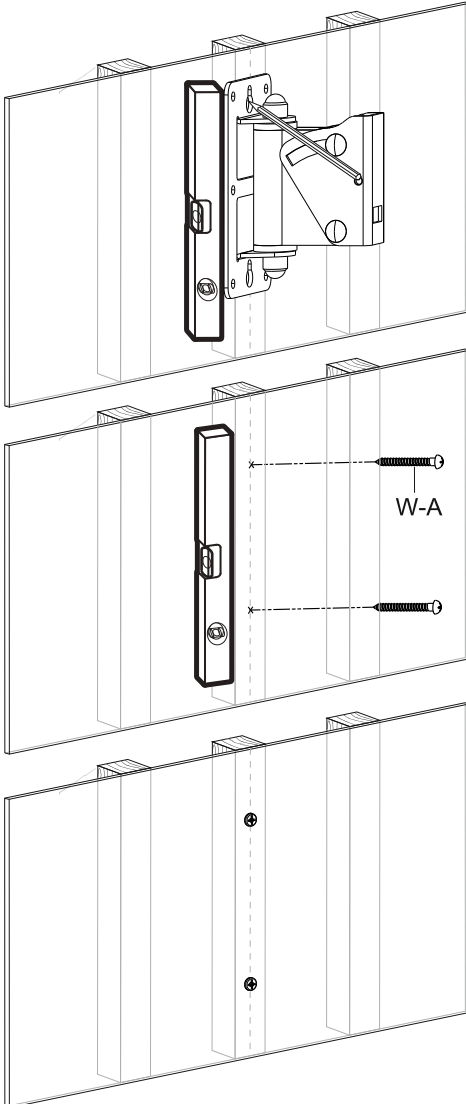

Beide Schrauben anziehen,
 3mm Abstand von der Wand.

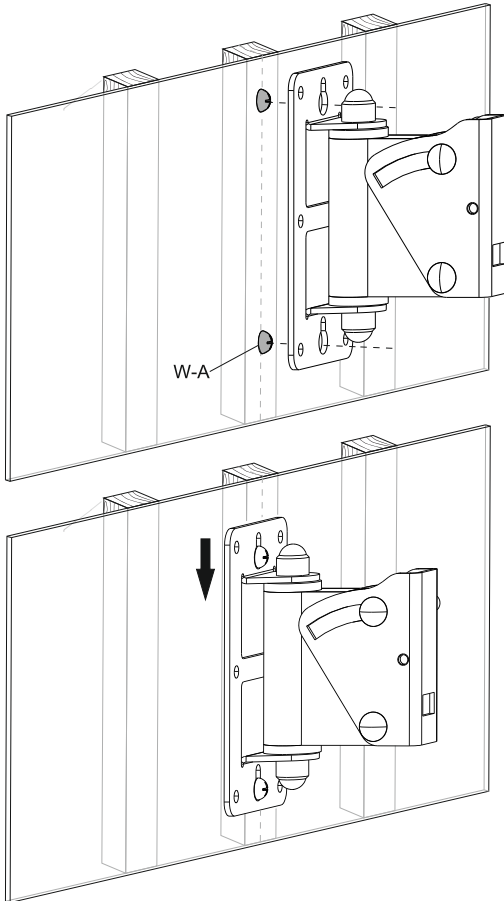

Beide Löcher der Wandplatte an den Schrauben in der Wand ausrichten, bis beide Schrauben im oberen Teil der tränenförmigen Montagelöcher sitzen.

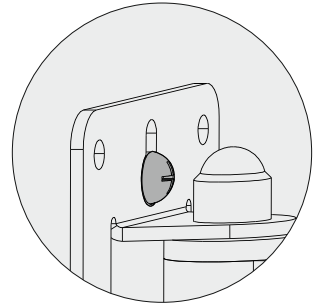

Wandplatte gerade ausrichten, alle Schrauben zur Sicherung anziehen.

WARNUNG

- Stellen Sie sicher dass die Montageschrauben sich im Zentrum der Balken befinden. Benutzen eines Balkenfinders ist sehr empfehlenswert.
- Monteure sind verpflichtet Montagezubehör für andere Arten von Montagesituationen zu liefern.
- Monteure müssen die Tragfähigkeit der Montagefläche überprüfen, ob diese die gesamte Last der Geräte und angeschlossenes Zubehör sicher aushält.

1b. Montage Auf Vollziegel oder Betonwand

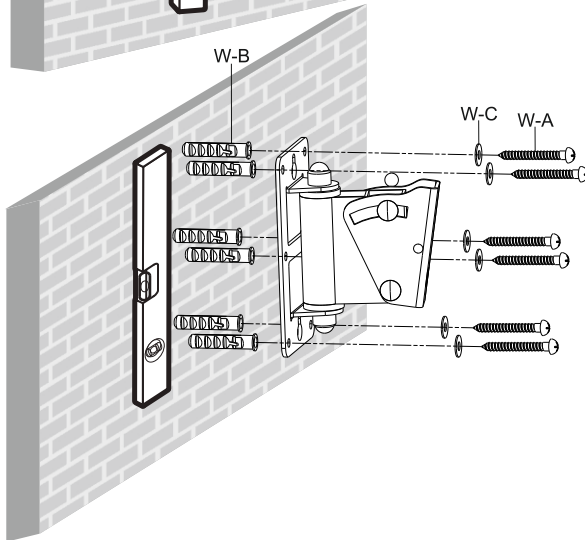
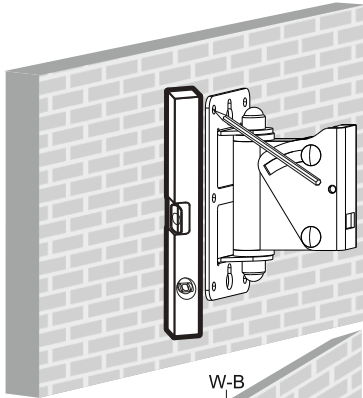
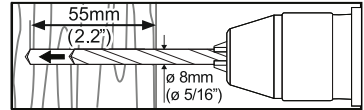
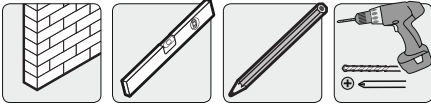

1
Finden und markieren
Sie die exakte Position
der Montagelöcher

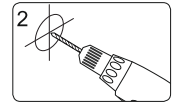

2
Löcher vorbohren

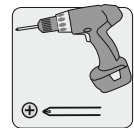
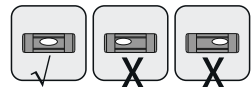

**Schrauben Sie
Wandplatte an
die Wand**

WARNUNG

- Bei der Montage der Wandhalterung auf Betonblocks, überprüfen Sie ob die Betondicke 1-3/8" (35 mm) beträgt, um Betondübel zu benutzen. Bohren Sie nicht in die Mörtelverbindungen! Stellen Sie sicher dass die Montage in einem soliden teil des Betonblocks erfolgt, im Allgemeinen 1" (25 mm) Minimum vom Rand des Blocks. Es wird empfohlen, beim bohren der Löcher, die Bohrmaschine auf eine langsame Geschwindigkeit einzustellen anstelle des Schlagbohrers, um das Ausbrechen der Löcher zu vermeiden beim auftreffen auf einen Hohlraum.
- Monteure müssen die Tragfähigkeit der Montagefläche überprüfen, ob diese die gesamte Last der Geräte und angeschlossenes Zubehör sicher aushält.

2. VESA Platte montieren

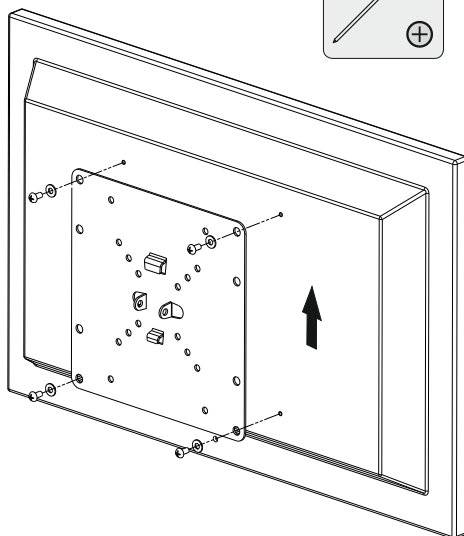
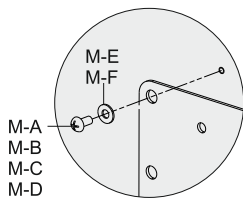
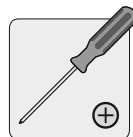
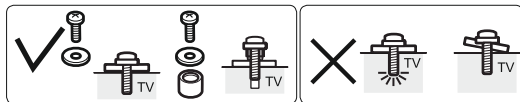

or

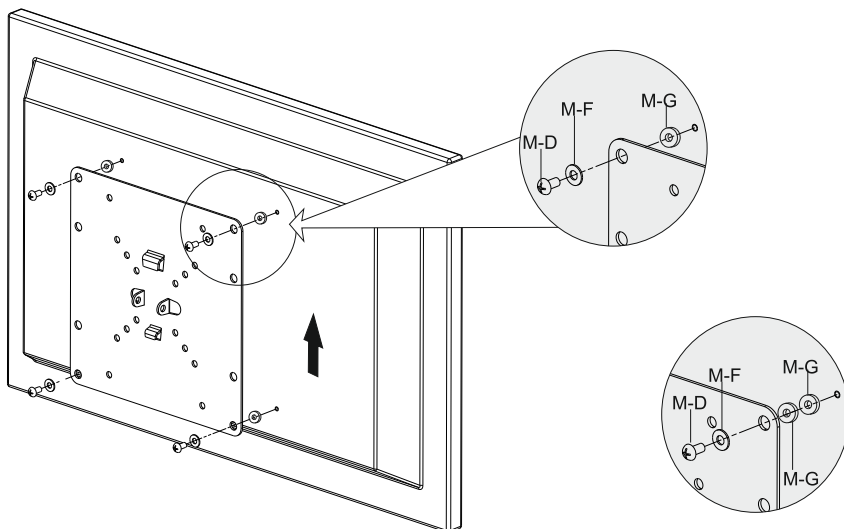

VESA Platte an das Display anschrauben.



Alle Schrauben anziehen, aber nicht überziehen.

3. Display an der Wandhalterung aufhängen

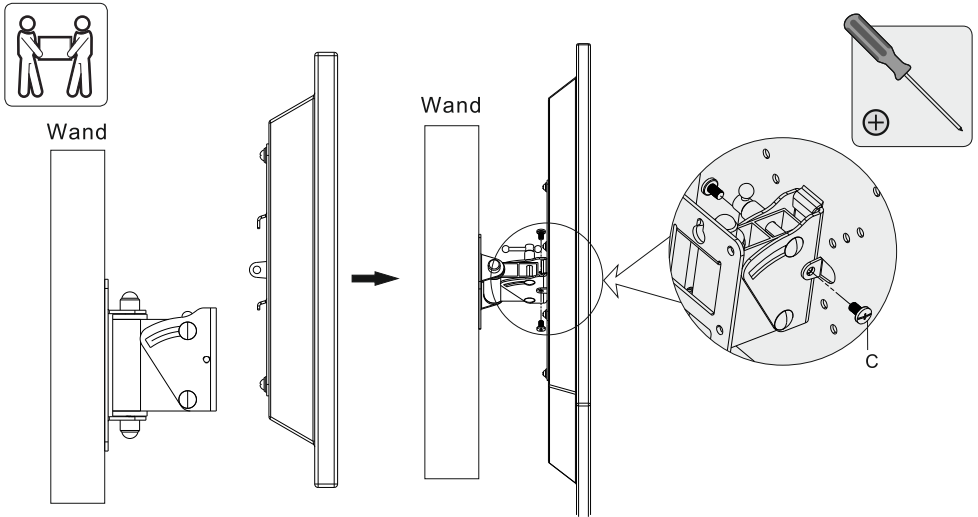

VESA platte (am Display befestigt) an der Wandhalterung aufhängen und alle Schrauben zur Sicherung anziehen.

4. Einstellung

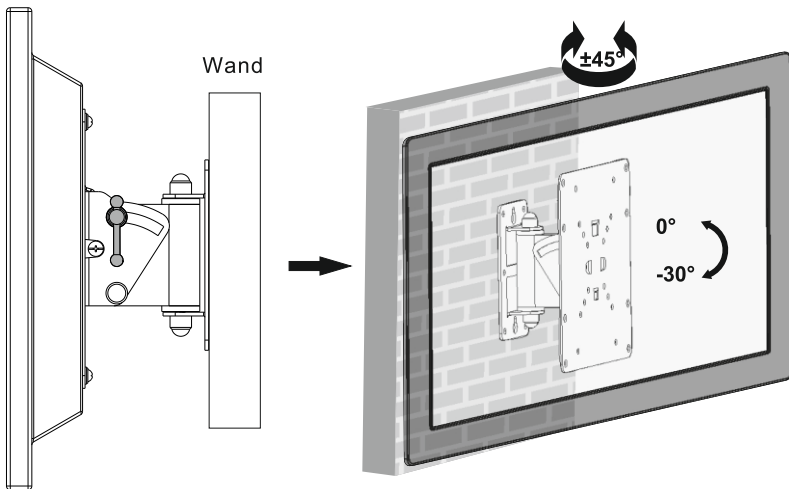

Einstellungsschraube lösen und gewünschte Neigung einstellen, danach Schraube wieder anziehen.

Wartung

Wartung

- Überprüfen Sie ob die Klammern sicher befestigt sind in regelmäßigen Abständen (zumindest alle drei Monate)
- Für etwaige Fragen wenden Sie sich an Ihren Händler.

Deutsch



Korrekte Entsorgung dieses Produkts (Elektromüll)

(Anzuwenden in den Ländern der Europäischen Union und anderen europäischen Ländern mit einem separaten Sammelsystem)

Die Kennzeichnung auf dem Produkt bzw. auf der dazugehörigen Literatur gibt an, dass es nach seiner Lebensdauer nicht zusammen mit dem normalen Haushaltsmüll entsorgt werden darf. Entsorgen Sie dieses Gerät bitte getrennt von anderen Abfällen, um der Umwelt bzw. der menschlichen Gesundheit nicht durch unkontrollierte Müllbeseitigung zu schaden. Recyceln Sie das Gerät, um die nachhaltige Wiederverwertung von stofflichen Ressourcen zu fördern

Private Nutzer sollten den Händler, bei dem das Produkt gekauft wurde, oder die zuständigen Behörden kontaktieren, um in Erfahrung zu bringen, wie sie das Gerät auf umweltfreundliche Weise recyceln können

Gewerbliche Nutzer sollten sich an Ihren Lieferanten wenden und die Bedingungen des Verkaufsvertrags konsultieren. Dieses Produkt darf nicht zusammen mit anderem Gewerbemüll entsorgt werden



Made in China für Lechpol Electronics Bv Provincialeweg 7, 3248 Lk Melissant, Holland



www.cabletech.pl